

# **HVM200**

## Human Vibration Meter Reference Manual



# **Larson Davis**

## **HVM200**

### **Reference Manual**

## Copyright

Copyright 2024, by PCB Piezotronics, Inc. This manual is copyrighted, with all rights reserved. The manual may not be copied in whole or in part for any use without prior written consent of PCB Piezotronics, Inc.

## Trademarks in this Manual

Android and the Google Play Store are trademarks of Google, LLC in the U.S. and in other countries. iTunes Store is a trademark of Apple, Inc. in the U.S. and in other countries. IOS is a registered trademark of Cisco Systems in the U.S. and in other countries. SoundAdvisor 831C is a trademark of PCB Piezotronics, Inc.

## Disclaimer

The following paragraph does not apply in any state or country where such statements are not agreeable with local law:

Even though PCB Piezotronics, Inc. has reviewed its documentation, PCB Piezotronics Inc. makes no warranty or representation, either expressed or implied, with respect to this instrument and documentation, its quality, performance, merchantability, or fitness for a particular purpose. This documentation is subject to change without notice, and should not be construed as a commitment or representation by PCB Piezotronics, Inc.

This publication may contain inaccuracies or typographical errors. PCB Piezotronics, Inc. will periodically update the material for inclusion in new editions. Changes and improvements to the information described in this manual may be made at any time.

## Safety

If the equipment is used in a manner not specified by Larson Davis, the protection provided by the equipment may be impaired.

## Recycling

PCB Piezotronics, Inc. is an environmentally friendly organization and encourages our customers to be environmentally conscious. When this product reaches its end of life, please recycle the product through a local recycling center or return the product to PCB at the following address:



PCB Piezotronics, Inc.  
Attn: Recycling Coordinator  
1681 West 820 North  
Provo, Utah, USA 84601-1341

## Warranty

For warranty information, refer to <https://www.larsondavis.com/warranty>.

# Table of Contents

Module 1	Introduction to HVM200-----	1
	1.1 Features	
	1.2 Standard Contents, Optional Kits, and Accessories	
Module 2	Getting Started-----	4
	2.1 Charging and Power	
	2.2 Installing the LD Atlas app	
	2.3 Installing the G4 LD Utility	
	2.4 Connecting HVM200 to a Mobile Device	
	2.5 Connecting the HVM200 to G4	
Module 3	Setting Up the Measurement-----	13
	3.1 Preparing the Sensor	
	3.2 Creating the Measurement Setup File	
Module 4	Making a Measurement-----	25
	4.1 Deploying the Sensor	
	4.2 Selecting the Sensor in G4 or LD Atlas	
	4.3 Making the Measurement	
	4.4 Downloading HVM200 Data	
	4.5 Working with RAW Data Files	
Module 5	Settings and Features Reference-----	40
	5.1 Setting/Syncing Meter Time and Date	
	5.2 Enabling/Disabling the HVM200 WiFi Signal	
	5.3 Upgrading Firmware or Options	
	5.4 Troubleshooting HVM200 External Memory	
Appendix A	Specifications-----	A-1
Appendix B	Adapter Resonance and Frequency Response Test-----	B-1
Appendix C	Glossary of Terms-----	C-1
Appendix D	Regulatory Compliance-----	D-1

# Chapter 1 Introduction to HVM200

---

## In this module:

1.1	Features	1
1.2	Standard Contents, Optional Kits, and Accessories	1
1.2.1	Optional Kits	
1.2.2	Accessories	

## 1.1 Features

---

FIGURE 1-1



The Larson Davis HVM200 Human Vibration Meter is designed for use in assessing vibration as perceived by human beings.

The HVM200 provides the following features:

- Whole body, hand-arm, and general vibration applications
- Wireless mobile interface
- Compact design for easy wear and convenient placement
- Connection and control of multiple meters via WiFi access
- LD Atlas app for configuring, measuring, and viewing vibration data of multiple meters on a mobile device
- 1/1 and 1/3 Octave Band Analysis available as a firmware option
- Data analysis and visualization using G4 LD Utility software

## 1.2 Standard Contents, Optional Kits, and Accessories

---

The HVM200 standard package includes the following contents:

- Human Vibration Meter and certificate (HVM200)
- Rechargeable Lithium Battery (BAT018)
- Power Supply and Adapters (PSA035)
- USB Type-A to micro-B USB Cable (CBL218)
- Accelerometer Cable; ¼-28, 4-pin connection (CBL217-01)
- Removable SD Memory in meter
- Larson Davis USB drive with G4 LD Utility Software and manual

## 1.2.1 Optional Kits

---

HVM200 is available to purchase in the following kits, which include accessories and options for your specific task:

- Kit for hand/arm vibration (HVM200-HA-40F) includes:
  - HVM200 Human Vibration Meter
  - Hard Shell Case (CCS047)
  - Hand/Arm Vibration Arm Band (CCS048-L)
  - Accelerometer (SEN040F)
  - Hand Adapter (ADP081A)
  - G4 LD Utility software (SWW-G4-HVM)
- Kit for whole body vibration (HVM200-WB) includes:
  - HVM200 Human Vibration Meter
  - Hard Shell Case (CCS047)
  - Accelerometer for measuring whole body vibration (SEN027)
  - G4 LD Utility software (SWW-G4-HVM)
- Kit for hand/arm and whole body vibration (HVM200-ALL-40F) includes:
  - HVM200 Human Vibration Meter
  - Hard Shell Case (CCS047)
  - Hand/Arm Vibration Arm Band (CCS048-L)
  - Accelerometer for measuring hand/arm vibration (SEN040F)
  - Accelerometer for measuring whole body vibration (SEN027)
  - Hand Adapter (ADP081A)
  - G4 LD Utility software (SWW-G4-HVM)

## 1.2.2 Accessories

---

The following optional accessories for HVM200 extend the capabilities of the standard instrument or kit:

### Standard Accessories

- 1/1 and 1/3 Octave Band Analysis firmware (HVM200-OB3)
- File recording of sampled RAW-format vibration data (HVM200-RAW)
- G4 software development kit (SWW-G4-SDK)

- Hard Shell Case for transport and protection of HVM200 and accessories (CCS047)
- Arm Band for wearing the HVM200 (CCS048-L)
  - Size Large / X-Large (CCS048-L) or Small / Medium (CCS048-S)



**Accelerometers:**

- Accelerometer for ADP063 palm adapter (SEN026)
- Accelerometer for whole body vibration, seat adapter, and adapter for whole-body vibration measurements (SEN027)
- Accelerometers for Hand-Arm vibration measurement (SEN040F, SEN041F)
- Accelerometer for Hand-Arm and general vibration measurements (SEN020)
  - **LEARN MORE** For more information on HVM200 accessories, including sensors, see **Appendix B Adapter Resonance and Frequency Response Test.**
- Various adapters for accelerometer placement (ADP063, ADP080A, ADP081A, and ADP082A)
- Cables for connecting meter to accelerometer (CBL217-05, CBL216, and CBL217-01)
- Hand-held shaker for vibrational measurement verification (394C06)

# Chapter 2 Getting Started

This module provides instructions for setting up and configuring HVM200 meters for use with the LD Atlas app and G4 LD Utility.

## In this module:

2.1	Charging and Power	4
2.1.1	Charging the HVM200	
2.1.2	Overview of Buttons and Indicators	
2.2	Installing the LD Atlas app	6
2.3	Installing the G4 LD Utility	7
2.4	Connecting HVM200 to a Mobile Device	7
2.4.1	Connecting via WiFi Access Point	
2.4.2	Connecting via WiFi Network	
2.5	Connecting the HVM200 to G4	11
2.5.1	Connecting the HVM200 to G4 LD Utility via USB	
2.5.2	Connecting the HVM200 meter to G4 LD Utility via IP Address	

## 2.1 Charging and Power

### 2.1.1 Charging the HVM200

Always charge the HVM200 fully prior to making a measurement as described here. The time to charge is 3–6 hours. For best performance, avoid leaving the battery drained for extended periods of time.

**Step 1.** Slide and remove the back battery cover from the HVM200 meter as shown in *Figure 2-1*.

**FIGURE 2-1 Remove Battery Cover**



**Step 2.** To insert the supplied battery into the HVM200, do the following:

- Slide the battery contacts against the meter power contacts.



**b.** Lower the other end of the battery into the tray.

**TAKE NOTE** Make sure the battery contacts are fully seated against the power contacts in the meter and that the battery lies flat in the tray.

**FIGURE 2-2 Insert Battery**



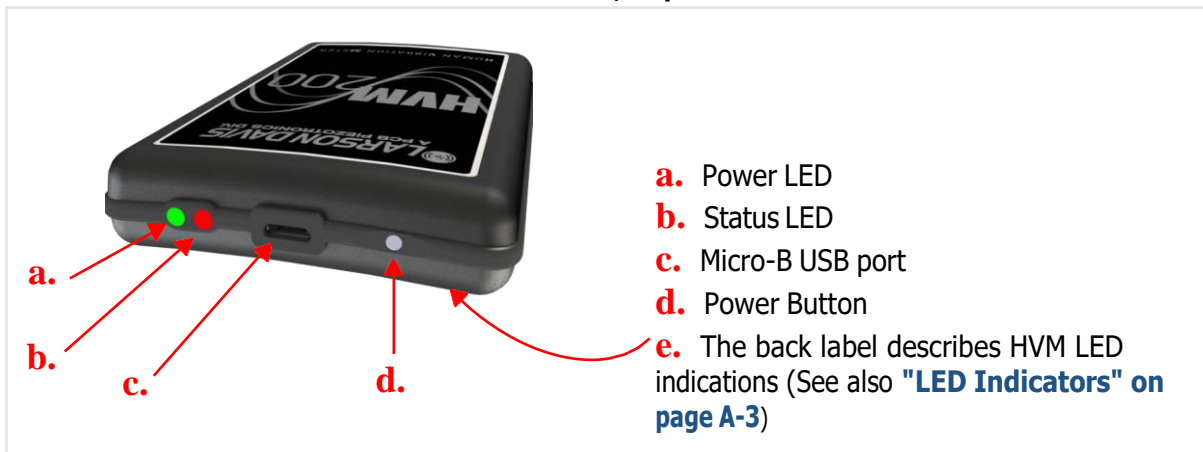
**Step 3.** Slide the back battery cover onto the HVM200.

**Step 4.** Insert one end of the supplied USB cable into the HVM200 Micro-B USB port and the other end to the included charger (PSA035). The **Power LED** is yellow when charging.

## 2.1.2 Overview of Buttons and Indicators

The HVM200 power button is on the right with the Power and Status LEDs on the left as shown in *Figure 2-3*.

**FIGURE 2-3 HVM200, Top view**



The power button is multi-functional, and provides each of the following functions:

**Table 2.1 HVM200 Power Button Functionality**

<b>Press</b>	<b>Action</b>	<b>Result</b>
Power on	Press and hold for 1 second	The Power LED is blue.
Start Measurement	When powered on, press once	The Status LED is green. The green LED will periodically blink.
Stop Measurement	Press when measuring	The Status LED is red to indicate that the measurement has stopped. The red LED will periodically blink.
Power Meter Off	When powered on, press and hold for 3 seconds	The Power LED is blue. Next, both LEDs go dark. The meter is powered off.

## **2.2 Installing the LD Atlas app**

---

You can control and access your HVM200 on your mobile device by using the LD Atlas app.

**Step 1.** On your mobile device, access either the Google Play<sup>®1</sup> Store or the Apple App Store<sup>®2</sup>.

**Step 2.** Search for “LD Atlas” and install



---

1. The Google Play Store is a trademark of Google LLC.  
2. The Apple Store is a trademark of Apple Inc., registered in the U.S. and other countries.

## **2.3 Installing the G4 LD Utility**

---

The G4 LD Utility software (G4) enhances the features, flexibility, and ease-of-use of Larson Davis instruments. It provides the following benefits:

- Measurement setup workspace
- Instrument calibration
- Computer-based control of the instrument
- Data download and manipulation
- Printing
- Data export to third-party software for post processing and analysis.

**Step 1.** Locate the G4 installer on the Larson Davis USB drive that came with the meter, or at <http://www.larsondavis.com/G4>.

**Step 2.** The install program prompts you for any required information and will install the G4 software

## **2.4 Connecting HVM200 to a Mobile Device**

---

There are two options for connecting your mobile device to the HVM200 as shown in this section.

### **In this section:**

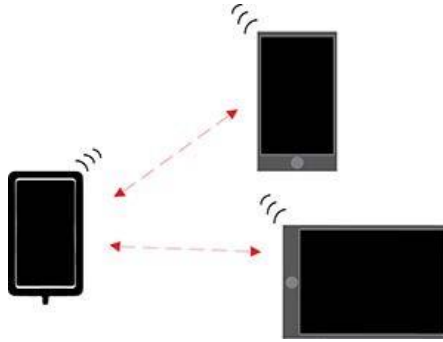
- [2.4.1 Connecting via WiFi Access Point](#)
- [2.4.2 Connecting via WiFi Network](#)

### **2.4.1 Connecting via WiFi Access Point**

---

When the LD Atlas app is installed on your mobile device, you can use the HVM200 as a WiFi access point to connect one or more mobile devices.

**FIGURE 2-4 HVM200 as a WiFi Access Point**



**Before you begin:**

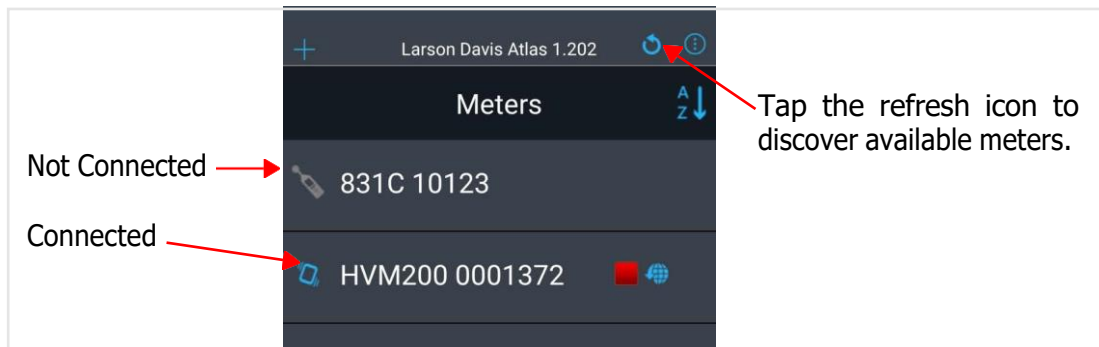
- Verify that WiFi is enabled on your device. You may need to disconnect from your current WiFi network to select the HVM200.
- For Android users on version 9+: Disable your mobile data.

**Step 1.** Open the WiFi settings on your mobile device.

**Step 2.** Tap to connect to the HVM200 WiFi network displaying the serial number of your meter. If no networks appear in the list; power off, then power on the HVM200.

**Step 3.** Launch the LD Atlas app. When connected, the meter icon in-line with the meter serial number displays in blue.

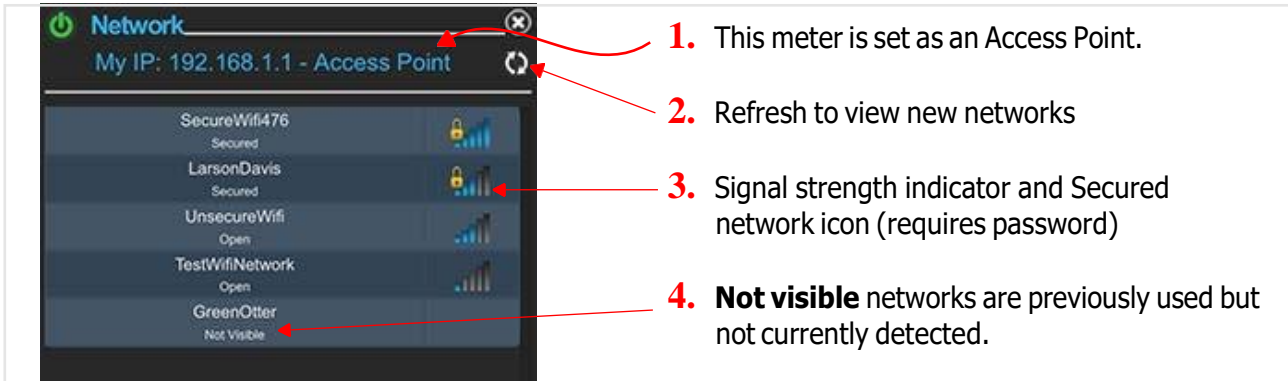
**FIGURE 2-5**



**Step 4.** Tap to select the "HVM <serial number>." This opens the meter interface in the app.

**Step 5.** Tap the **Menu icon**  → **WiFi Settings**, the Access Point IP address displays at the top of the screen under the **Network** heading.

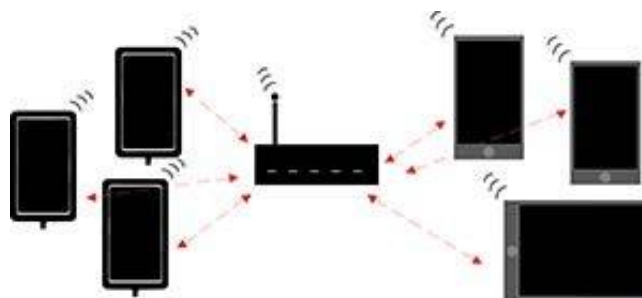
**FIGURE 2-6 Network Settings**



## 2.4.2 Connecting via WiFi Network

If a WiFi-enabled router is within range, connect one or more HVM200 units and one or more mobile devices to the same WiFi network. The HVM200 supports WPA and WPA2 WiFi security.

**FIGURE 2-7 Mobile Connections**



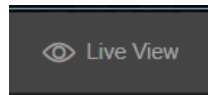
### Before you begin:

- Connect your HVM200 to G4 via USB. For help with this, see [2.5.1 Connecting the HVM200 to G4 LD Utility via USB](#).

**Step 1.** Launch G4, and click on your "HVM <serial number>" in the Meters list to open meter details.

**Step 2.** Access the HVM200 meter view by clicking on Live View

**FIGURE 2-8 Live View Header with Icon**



**Step 3.** Tap the **menu icon**  and select **Setup WiFi** from the Menu that opens.

**Step 4.** Select an available network that you will connect all devices to.

**TAKE NOTE** Networks are listed in the order of greatest signal strength. If no network appears in the list, click the Refresh button icon (see *Figure 2-6*).

- To connect to a hidden network, click **Add Network** and provide the network name. See section **2.4.1**, Step 3 for more information.
- If you already entered a password and saved a network, the HVM200 automatically connects to the network with the greatest signal strength.

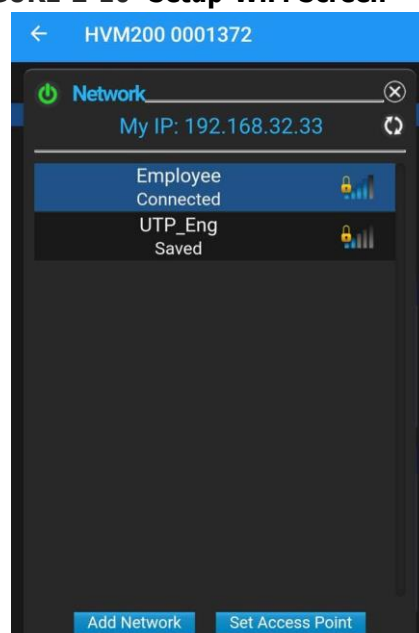
**Step 5.** If needed, enter the network password, and click **Add**.

**FIGURE 2-9 Enter Network Password**



**Step 6.** Verify your network connection details by clicking on the newly added network in the list. The connected network displays at the top of the screen under the **Network** heading.

**FIGURE 2-10 Setup WiFi Screen**



## 2.5 Connecting the HVM200 to G4

---

G4 LD Utility (G4) provides features for setup, measurement, data download, and data viewing with Larson Davis products, including HVM200.

### In this section:

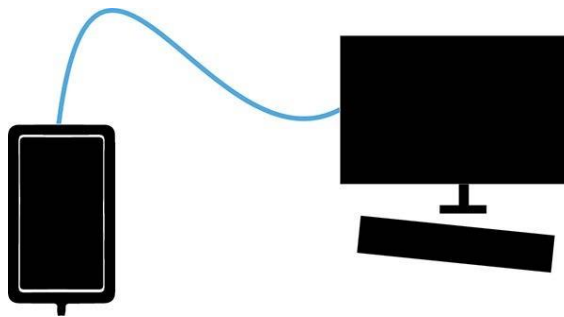
- [2.5.1 Connecting the HVM200 to G4 LD Utility via USB](#)
- [2.5.2 Connecting the HVM200 meter to G4 LD Utility via IP Address](#)

### 2.5.1 Connecting the HVM200 to G4 LD Utility via USB

---


Using a Micro-B USB cable, you can directly connect your meter to your PC and operate it using G4.

**FIGURE 2-11 USB Cable Connection**



**Step 1.** Connect the HVM200 to a PC with the provided USB to Micro-B cable (CBL218) and launch G4. After a few moments, your HVM200 displays as active in the G4 Meters Panel.

**Step 2.** Click on the name of your meter in the Meters Panel. This opens the Meter tab.

**Step 3.** Click  **Live View**. The Live View in G4 presents an interface similar to the LD Atlas app.

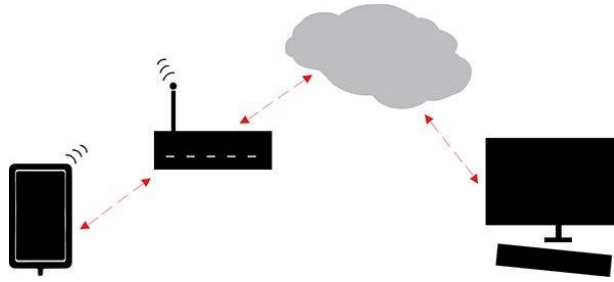
**LEARN MORE** For more information on working with G4 and the Meters Panel, see the **G4 LD Utility Software Manual**. To access it within G4, go to **Help → Manuals**.

### 2.5.2 Connecting the HVM200 meter to G4 LD Utility via IP Address

---

A PC that is connected to the same WiFi network as the HVM200 can connect to the meter.

**FIGURE 2-12 Connecting via IP Address**



**Before you begin:**

- Make sure the meter connection to G4 is active.
- Verify that Port Forwarding is enabled on your gateway or local router.
- Locate the IP address of the gateway or router to enter into G4 as shown below.

**Step 1.** Connect the HVM200 to a WiFi network with Internet access as shown in [2.4.2 Connecting via WiFi Network](#).

**Step 2.** Launch G4 and wait for the HVM200 to appear active in the Meters panel.

**Step 3.** If the meter does not show in the Meters panel, you can try manually adding the meter via IP address by tapping the three dots menu to the right of Meters and select Add Meter. This opens the Add TCP Connected Meter screen.

- Enter information as need in the following fields, then tap the plus button to connect:
- Enter a Connection Name (Optional).
- IP Address/Hostname
- Port

**TAKE NOTE** IP address is the only field officially required to add a meter.

**Step 4.** G4 connects to the HVM200, and the "HVM200 <serial number>" displays as active on the Meters screen. This may take a few minutes.

**LEARN MORE** For more information on working with G4, refer to the *G4 LD Utility Manual*. In G4, go to **Help** → **Manuals**.

**Recommended next step:**

- [Chapter 3 Setting Up the Measurement](#)



# Chapter **3** Setting Up the Measurement

---

## In this module:

3.1	Preparing the Sensor-----	13
3.1.1	Connecting Sensor Cable to the HVM200	
3.1.2	Connecting Sensor Cable to the Adapter	
3.1.3	Configuring the Sensor	
3.2	Creating the Measurement Setup File -----	18
3.2.1	Performing a Calibration Check	
3.2.2	Creating a Setup File by Using Your Mobile Device	
3.2.3	Setting the Active Setup File	

## **3.1 Preparing the Sensor**

---

In this section, connect the sensor and HVM200. Once cables are connected, select the sensor in G4 or LD Atlas as shown here. Complete each section in the order it's presented unless directed otherwise.

### In this section:

- **3.1.1 Connecting Sensor Cable to the HVM200**
- **3.1.2 Connecting Sensor Cable to the Adapter**
- **3.1.3 Configuring the Sensor**

### **3.1.1 Connecting Sensor Cable to the HVM200**

---

The sensor cable (CBL216) connects between the 1/4-28 HVM200 connector and the sensor. Both end connectors have a gold cable lock design that secures the cable to the sensor for the most accurate vibration measurement. The cable will only connect to the HVM200 and the sensor when precisely aligned as shown in this section.

**Step 1.** Place the HVM200 connector port gently into the cable connector while aligning the black portion of the cable connector with the dimple on the HVM200 connector.

**Step 2.** Hand-tighten the nut over the connection.

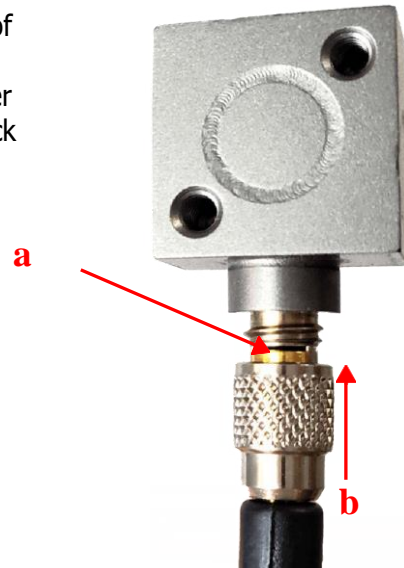
### 3.1.2 Connecting Sensor Cable to the Adapter

---

Connecting the sensor cable to the accelerometer is similar for all different types of adapters, follow the instructions in *Figure 3-1*.

**FIGURE 3-1 Connecting Sensor Cable to Accelerometer**

- a.** Place the accelerometer into one end of the cable, so the connector cut-out aligns with the gold cable lock. The accelerometer connector dimple will line up with the black portion of the cable connector
- b.** Hand-tighten the nut over the connection.



Choose the section that refers to the adapter you'll use for the measurement.

#### **In this section:**

- [Using the Palm Adapter](#)
- [Using the Arm Band Adapter](#)
- [Using Other Adapters](#)

## Using the Palm Adapter

**Step 1.** Feed one end of the cable (CBL216) from the bottom to the top of the palm adapter as shown in *Figure 3-2*.

**FIGURE 3-2 Cable Path for Palm Adapter**



**Step 2.** Connect the accelerometer to CBL216 as shown in *Figure 3-1*.

**Step 3.** Configure the sensor as shown in **3.1.3 Configuring the Sensor**.

## Using the Arm Band Adapter

**Step 1.** Insert the HVM200 and cable into the pocket with the cable first, so that the cable extends through the bottom of the pocket. When applied to the subject, the end with the transparent cover should be farthest from the hand.

**Step 2.** Connect the accelerometer and cable as shown in *Figure 3-1*.

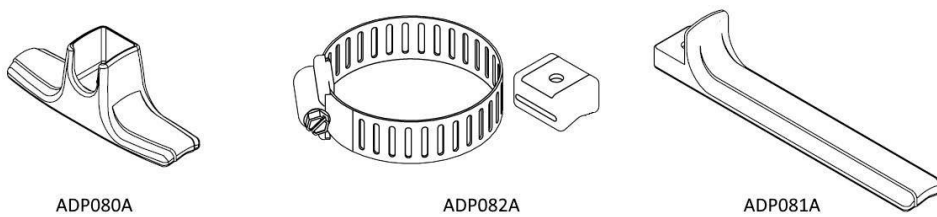
**Step 3.** Configure the sensor as shown in **3.1.3 Configuring the Sensor**.



## Using Other Adapters

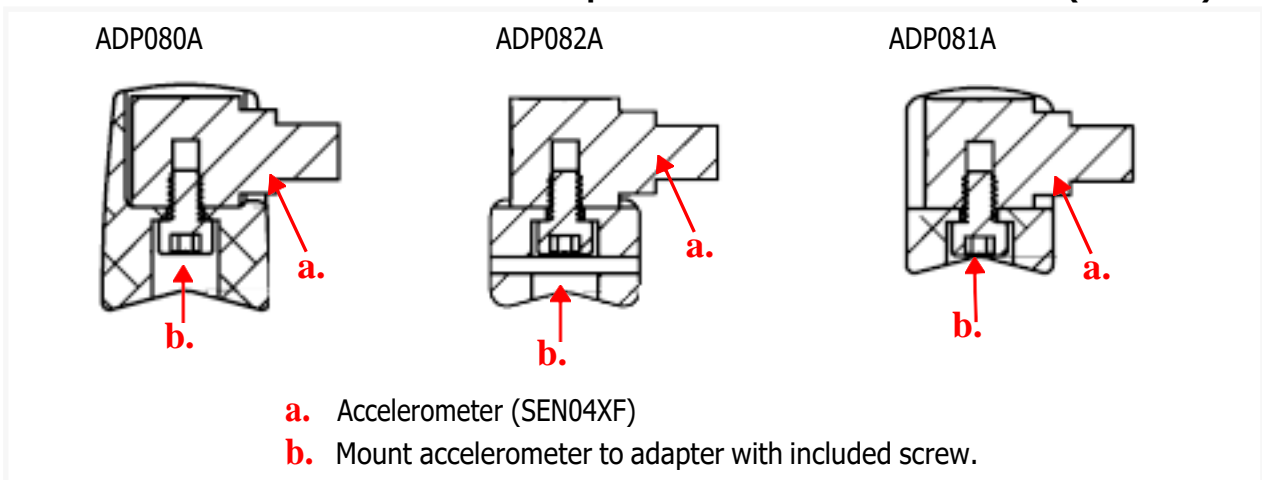
This section shows how to secure the accelerometer to the following adapters: hand adapter (ADP080A), handle adapter (ADP081A), clamp adapter (ADP082A).

**FIGURE 3-3 Other Adapters**



**Step 1.** Connect the accelerometer to the adapter as shown in *Figure 3-1*.

**FIGURE 3-4 Adapter Placement with Accelerometer (SEN04XF)**



**Step 2.** Connect the accelerometer and cable as shown in *Figure 3-1*.


**Step 3.** Configure the sensor as shown in **3.1.3 Configuring the Sensor**.

### 3.1.3 Configuring the Sensor

In this section, configure the sensor in G4 or LD Atlas.

**Step 1.** If the HVM200 is not already turned on, press the power button once. The Power LED turns blue.

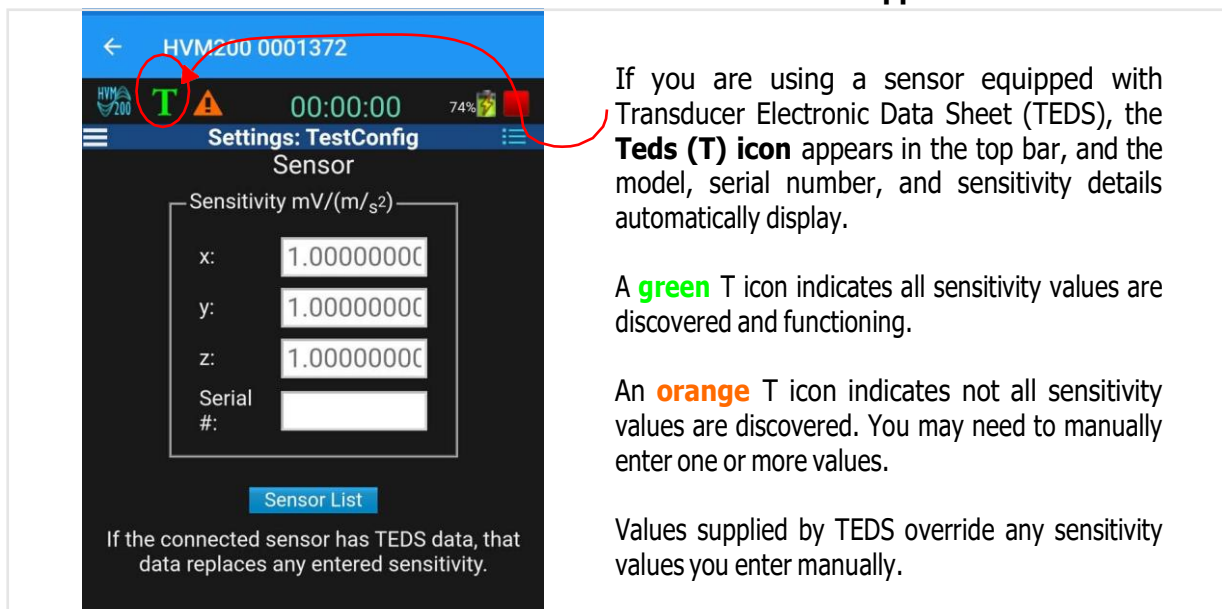
**Step 2.** Connect the HVM200 to G4 or LD Atlas via the included USB cable (CBL218).

**Step 3.** Select the **Setup Manager** in G4 or LD Atlas (In Atlas, tap the **menu icon**  → **Settings**).

**LEARN MORE** For more information on working with G4 tabs and settings, refer to the *G4 LD Utility Software Manual*. In G4, go to **Help** → **Manuals**.

**Step 4.** Highlight a measurement configuration in the list, and tap or click the bottom-right arrow to access the **Sensor** page. *Figure 3-5* shows the currently connected sensor details.

**FIGURE 3-5 TEDS Sensor Details in LD Atlas App**



**Step 5.** If your chosen sensor is not TEDS enabled, do the following:

- Select **Sensor List**. This opens a list of known sensors. If your chosen sensor is shown in the list, highlight and click or tap **Select**.
- Enter the sensor information—including **Sensitivity** for the x, y, and z axes—then select **Add**.

**TAKE NOTE** Sensor information is usually listed on the calibration certificate that comes with the sensor.

- Select the sensor when it appears in the list, and click or tap **Select**. The sensitivity values automatically appear on the Sensor page.

**Step 6.** Click or tap **Close** and **Save** to return to the Setup Manager list.

## 3.2 Creating the Measurement Setup File

---

### 3.2.1 Performing a Calibration Check


---

#### Before you begin:

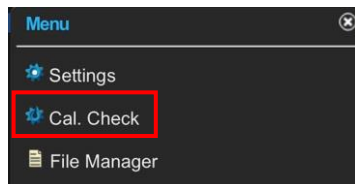
- A calibration check requires a hand-held shaker, such as the PCB Model 394C06. To view shaker options, go to [www.pcb.com/Sensor-Calibration/Portable-Vibration](http://www.pcb.com/Sensor-Calibration/Portable-Vibration).
- The Calibration check frequency will be dependent on the shaker you use. For the 394C06, it is 159.2 Hz.
- Set sensitivity values for the x, y, and z-axes on the **Sensor** tab. For more information, see [3.1.3 Configuring the Sensor](#).
- If applicable, stop the measurement in progress.

**Step 1.** Launch G4 on your PC or the LD Atlas app on your mobile device.

**Step 2.** In G4, connect to your HVM200, then click the **Live View**. For help connecting, see "Connecting the HVM200 to G4".

**Step 3.** Click the **menu icon**  and select **Cal. Check** in the menu that appears.

**FIGURE 3-6 Select Cal. Check**



**Step 4.** Enter the **Reference** value for the shaker you will use to perform the calibration check, then click **Set**.

**TAKE NOTE** The reference value is usually provided in the shaker documentation. The units (i.e. g, m/s<sup>2</sup>) to use for entering this reference will follow the display units setting of the meter.

**Step 5.** Attach the transducer to your shaker so that the axis you wish to check is oriented properly.

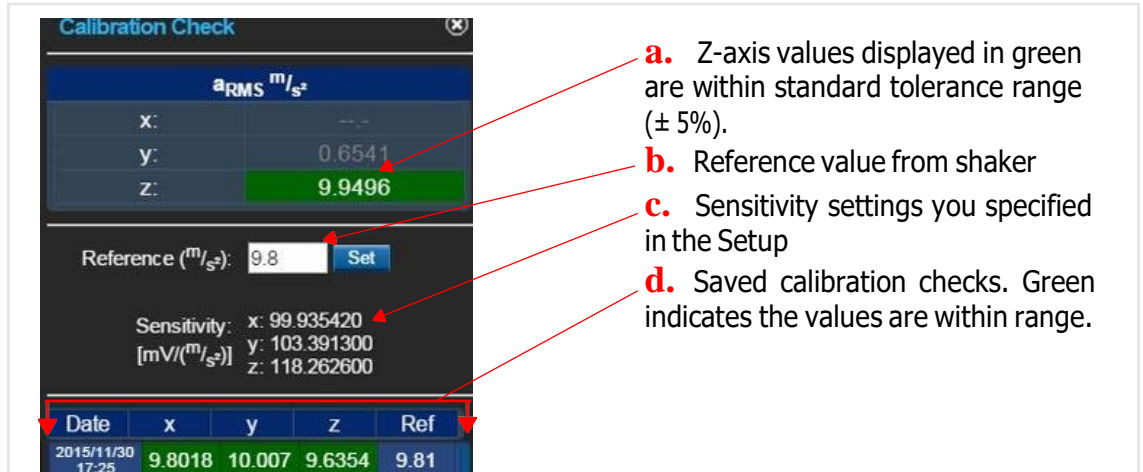
**Step 6.** Start the shaker and note the **a<sub>rms</sub>** values for each axis as shown in *Figure 3-7*, according to the following criteria:

- Values are gray when the level has not been checked. (See "Calibration Check")
- Values are white during the check.
- Values are red if the axis measurement is complete and the level varies from the reference value by more than  $\pm 5\%$ .
- Values are green if the axis measurement is complete and the level is within  $\pm 5\%$  of the reference value.

**TAKE NOTE** During the calibration check, the filter is automatically set to "Fb-weighting," then restored to the former value when the check is complete.

**Step 7.** Repeat the process for each axis on the accelerometer as shown in *Figure 3-2*.

**FIGURE 3-7 Calibration Check**



**LEARN MORE** If you are using G4, the last 2 saved calibration checks are displayed in measurement spreadsheets. For more information, in G4 go to **Help** → **Manuals** → **G4 LD Utility**.

**Step 8.** To save the calibration check, close the **Calibration Check** dialog box.

## 3.2.2 Creating a Setup File by Using Your Mobile Device

The HVM200 includes several default measurement setups in the Settings list. You can also create your own custom setup file as shown in this section. When this section is complete, be sure to make the new Setup file Active as shown in **3.2.3 Setting the Active Setup File**.


### In this section:


- **Part 1: Creating the Setup File**
- **Part 2: Choosing Values On the Setup Page**
- **Part 3: Choosing Values On the Schedule Page**
- **Part 4: Choosing Values On the Misc Page**
- **Part 5: Choosing Values On the Tools Page**
- **Part 6: Verifying Installed Options**

### Part 1: Creating the Setup File

To create a new setup file, modify the default setup and save it with a different name. This section shows instructions for using LD Atlas, however, you may also follow these steps in G4.

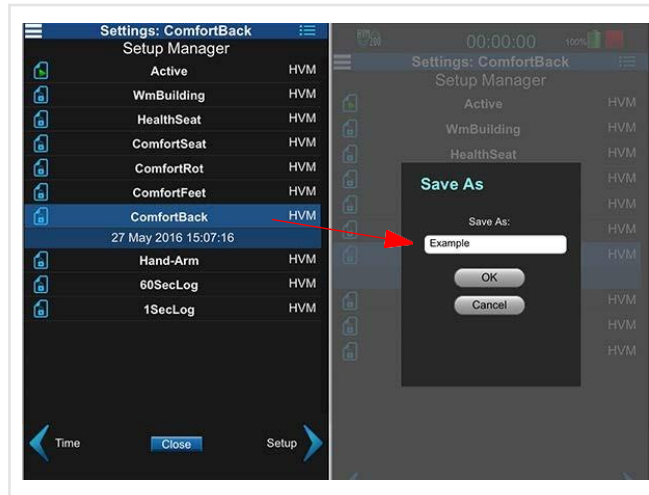
#### Before you begin:

- Connect your HVM200 in G4 or LD Atlas. Connected meters display the **blue meter icon**  in the Meters Panel. For more information, see **2.4 Connecting HVM200 to a Mobile Device** or **2.5 Connecting the HVM200 to G4**.

**Step 1.** In LD Atlas or G4, open the meter screen, tap the **menu icon** , then tap **Settings**.

**Step 2.** Tap and hold on a default Setup File in the **Settings** list. In the pop-up that appears, tap **Save As** and enter a name for the measurement setup.

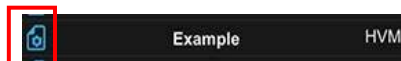
**FIGURE 3-8 Naming the Setup File**




**TAKE NOTE** If you return to the Setup Manager tab from a Settings page, the app prompts you to save settings. Tap **Yes** to apply the changes to the setup.

**Step 3.** In the Setup Manager list, locate your new setup file. Tap the blue file icon in-line with your new setup file.

**FIGURE 3-9 Select New Setup File**



## Part 2: Choosing Values On the Setup Page

**Step 1.** With your new Setup highlighted in the Setup Manager list, use the **arrow icon**  in the bottom right to move to the **Setup** page.

**Step 2.** Select values for the following options on the Setup page:

- **Operating Mode:** Vibration, Hand/Arm, or Whole Body; Choose the mode appropriate for your measurement application
- **Store Interval Time:** This is the period of time data is collected, averaged, and stored before starting a new sample.
- **Store Raw Data:** Available when you purchase and install the Raw Data option (HVM200-RAW). With Store Raw Data enabled, the supplied HVM200 memory card stores individual file


**FIGURE 3-10**





sizes up to 2 GB and more than 6 hours of data. When not enabled, the card stores approximately 8000 hours of data. For more information, see [4.5 Working with RAW Data Files](#).



- **Weighting:** For each axis, “Wh-weighting” is the default for all axes in Hand/Arm Mode. For more information on operating modes and specified weighting curves, see [“Frequency Weighting Curves” on page A-9](#).

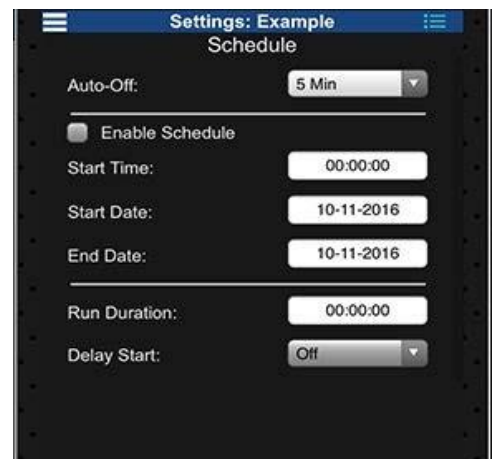
**Step 3.** If your Setup is complete, tap **Close** to save it, then see [3.2.3 “Setting the Active Setup File” on page 24](#). You may also tap the **page arrow icon**  to continue defining the Setup.

### Part 3: Choosing Values On the Schedule Page

If you want the HVM200 to automatically make a measurement at a scheduled time, select values on the Schedule page.

**FIGURE 3-11 LD Atlas Schedule Page**

**Step 1.** Navigate to the Schedule page of the Setup file. To do this, either, tap the **Setup menu icon** , or tap the **page arrow icon**  until the Schedule page displays.




**Step 2.** If you want the meter to turn off after making a measurement, select a value from the **Auto-Off** drop-down menu. Auto-Off is the amount of time the HVM200 remains on and inactive. If a measurement begins, the time to Auto-Off resets.

**Step 3.** Select the checkbox in-line with **Enable Schedule**.

**Step 4.** If desired, enter values for any of the following settings:



- **Start Time:** If a manual measurement runs into the start time of a scheduled measurement, the scheduled measurement will not occur.
- **Start Date**
- **End Date**
- **Run Duration:** When Run Duration is set to “00:00:00,” the meter runs until manually stopped. If it is set to any other time, the meter stops after acquiring data for the selected amount of time.
- **Delay Start:** Delays the start of a measurement for the specified time after the start time.

**Step 5.** If your Setup is complete, tap **Close** to save it, then see **3.2.3 "Setting the Active Setup File" on page 24**. You may also tap the **page arrow icon**  to continue defining the Setup.

#### Part 4: Choosing Values On the Misc Page

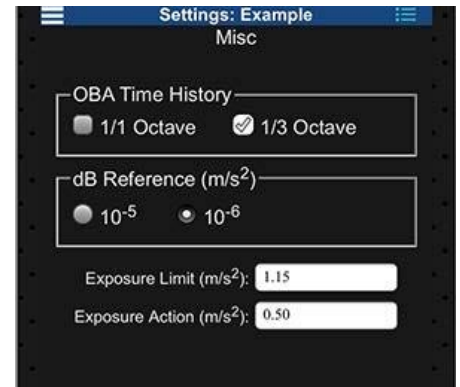
Select values for miscellaneous measurement settings on the Misc Page as shown in this section.

**FIGURE 3-12 LD Atlas, Setup Misc Page**

**Step 1.** Navigate to the **Misc** page of the Setup file. To do this, either, tap the **Setup menu** , or tap the **page arrow icon**  until the Misc page displays.


**Step 2.** If you've purchased the optional Octave Band Analysis feature (HVM200-OB3), select **1/1 Octave** or **1/3 Octave**.

**Step 3.** If you want to specify a **dB Reference** pressure, select an option.





**Step 4.** If desired, specify **Exposure Limit** and **Exposure Action** levels.

**TAKE NOTE** Default values are set per EU Physical Agents Directive (2002/44/EC). Enter values here for other standards or for your custom requirements.

**Step 5.** If your Setup is complete, tap **Close** to save it, then see **3.2.3 "Setting the Active Setup File" on page 24**. You may also tap the **page arrow icon**  to continue defining the Setup.

#### Part 5: Choosing Values On the Tools Page

**Step 1.** Navigate to the **Tools** page of the Setup file. To do this, either, tap the **Setup menu** , or tap the **page arrow icon**  until the Tools page displays.


**Step 2.** If desired, customize the **Display Units**. If you change this, also review the dB Reference level on the Misc page.

**Step 3.** If desired, choose a new **Integration** option. Selecting "Single integration" calculations converts acceleration values into velocity values; selecting "Double integration" converts acceleration values into displacement values.

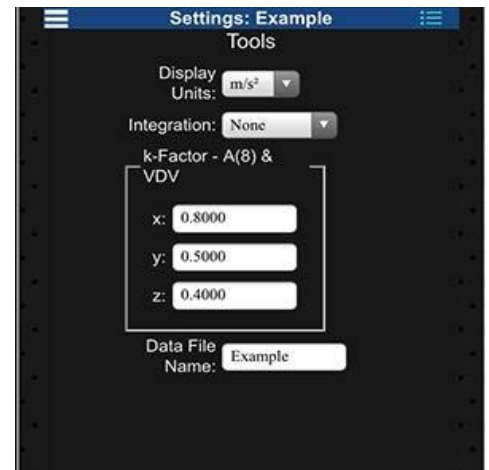
**Step 4.** To specify the **k-Factor** for each axis, enter the desired values. For whole body measurements, the HVM200 multiplies the specified k-Factor by the instantaneous acceleration for each axis to produce the summation ( $\Sigma$ ) value in the Overall view of the app.

**TAKE NOTE** K-factors are ignored for general vibration and hand/arm measurements. For more information, see the entry for "Summed Instantaneous Acceleration" in "[Glossary of Terms](#)" on page C-1.


**Step 5.** If desired, enter a **Data File Name**. Any resulting data files from this Setup will be saved with this value as a prefix.

**Step 6.** If your Setup is complete, tap **Close** to save it, then see [3.2.3 "Setting the Active Setup File" on page 24](#). You may also tap the **page arrow icon**  to continue defining the Setup.

**FIGURE 3-13** LD Atlas, Setup Tools




## Part 6: Verifying Installed Options

**Step 1.** From the Setup Manager Tools page, use the **arrow icon**  to move to the **Options** page.

**Step 2.** Verify that your purchased option is displayed and selected in the list. You can also deselect this feature if the a measurement does not require the optional data.  
If you plan to create RAW format data files, be sure to select the checkbox in-line with **Raw Data**.

**LEARN MORE** For more helpful information on storing and using RAW format files, see [4.5 "Working with RAW Data Files" on page 34](#).

**Step 3.** If your Setup is complete, tap **Close** to save it, then see [3.2.3 "Setting the Active Setup File" on page 24](#). You may also tap the **page arrow icon**  to continue defining the Setup.


### Recommended next step:

- [3.2.3 Setting the Active Setup File](#)

## 3.2.3 Setting the Active Setup File

### Before you begin:

- Customize the setup file as shown in [3.2.2 Creating a Setup File by Using Your Mobile Device](#).


**Step 1.** Within the Setup Manager, navigate to the list of Setup files. To do this, tap the **page arrow icon**  until the Setup list displays.

**FIGURE 3-14 List of Setup Files**



**Step 2.** Tap and hold the name of the Setup you want to use for the next measurement, then tap **Set as Active** in the menu that appears.

**Step 3.** Always verify the sensor settings after saving a new setup file. To do this, do the following:

- Tap to select the "Active" setup in the Setup Manager list.
- Tap the **page arrow icon**  until the **Sensor** page displays.
- Verify that the **Serial #** and **Sensitivity** values are what you expect for the chosen accelerometer. When using TEDS sensor, values are automatically verified; just verify the Serial #.

**TAKE NOTE** If your accelerometer does not have TEDS capability and you have not specified the settings, see [3.2 Creating the Measurement Setup File](#).

# Chapter 4 Making a Measurement

---

This module shows how to perform a vibration measurement using the HVM200, with LD Atlas app on a mobile device, and G4 LD Utility on the PC. Review sections in this module that utilize the sensor and accessories applicable to your measurement.

## In this module:

4.1	Deploying the Sensor .....	25
4.2	Selecting the Sensor in G4 or LD Atlas .....	28
4.3	Making the Measurement.....	29
4.4	Downloading HVM200 Data.....	34
4.5	Working with RAW Data Files .....	34

## 4.1 Deploying the Sensor

---

For every configuration, it is critical to rigidly secure the sensor with the suitable adapter. If the sensor is not rigidly secured or the adapter is not tight against the vibrating surface, it may result in measurement inaccuracies.

Select your adapter from the following list for more information:

- [4.1.1 Positioning the Armband Adapter and Accelerometer](#)
- [4.1.2 Positioning the Clamp Adapter and Accelerometer](#)
- [4.1.3 Positioning the Hand Adapter and Accelerometer](#)
- [4.1.4 Positioning the Handle Adapter and Accelerometer](#)
- [4.1.5 Positioning the Palm Adapter and Accelerometer](#)
- [4.1.6 Positioning for Whole Body Vibration With Seat Adapter](#)

### 4.1.1 Positioning the Armband Adapter and Accelerometer

---

For an arm vibration measurement, complete this section.

#### Before you begin:

- Prepare the accelerometer cable (CBL216) as shown in [\*\*3.1 "Preparing the Sensor" on page 13.\*\*](#)

**Step 1.** Attach the Arm Band (CCS048) on the person being monitored. When applied to the subject, the transparent cover should be farthest from the hand.

**Step 2.** Insert the HVM200 into the meter pocket and thread the attached sensor cable through the bottom of the pocket.

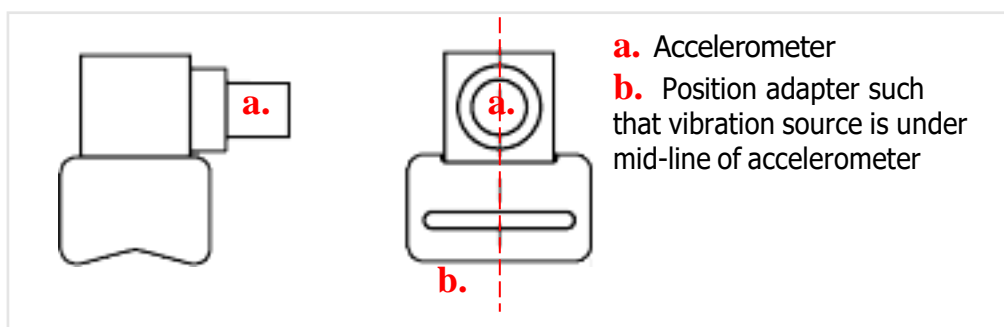


**FIGURE 4-1 Arm Band**

### 4.1.2 Positioning the Clamp Adapter and Accelerometer

---

**FIGURE 4-2 Positioning the Clamp Adapter**

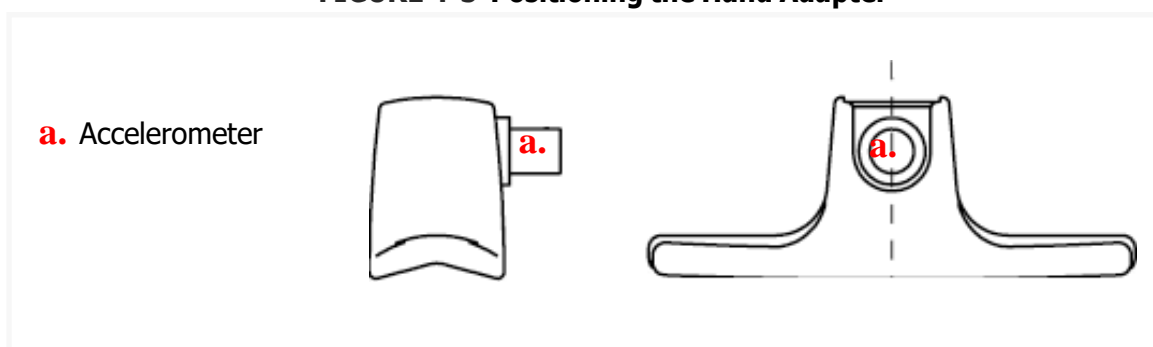


### 4.1.3 Positioning the Hand Adapter and Accelerometer

---

**Step 1.** Position the Larson Davis hand adapter in the hand of the person being monitored.

**FIGURE 4-3 Positioning the Hand Adapter**



**Step 2.** Secure the HVM200, using the arm band or other similar method, so that it stays near the hand in a place where it won't fall.

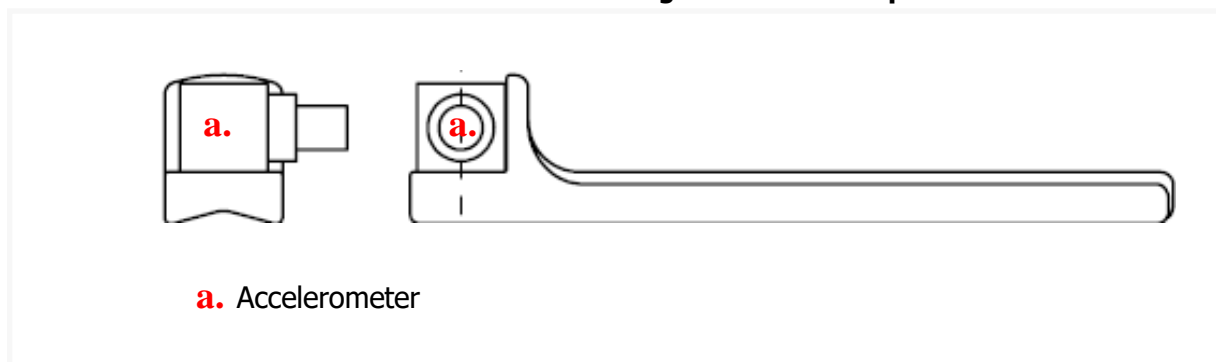
**TRY THIS** The arm band provides a secure place for the HVM200 during a measurement.

#### 4.1.4 Positioning the Handle Adapter and Accelerometer

---

- Step 1.** Attach the Larson Davis hand adapter on the person being monitored. The end with the transparent cover should be farthest from the hand.

**FIGURE 4-4 Positioning the Handle Adapter**



- Step 2.** Secure the HVM200, using the arm band or other similar method, so that it stays near the hand in a place where it won't fall.

**TRY THIS** The arm band provides a secure place for the HVM200 during a measurement.

#### 4.1.5 Positioning the Palm Adapter and Accelerometer

---

- Step 1.** Attach the Larson Davis palm adapter to the person being monitored.

- Step 2.** Secure the HVM200, using the arm band or other similar method, so that it stays near the hand in a place where it won't fall.

**TRY THIS** The arm band provides a secure place for the HVM200 during a measurement.

#### 4.1.6 Positioning for Whole Body Vibration With Seat Adapter

---


For whole body vibration measurements using the Seat Adapter (SEN027), follow these steps.

**TAKE NOTE** The Seat Adapter is sold with the SEN027 accelerometer already installed in the adapter and with the cable already connected to the accelerometer.

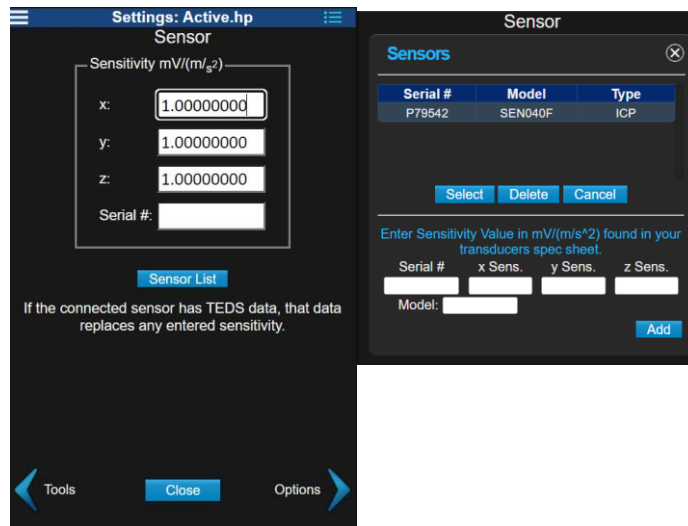
- Step 1.** Place the seat adapter where the person being monitored will sit.
- Step 2.** Connect CBL217-01 to the HVM200 on one end and the seat adapter cable on the other end.
- Step 3.** Secure the HVM200 in a secure location where it won't fall.

## 4.2 Selecting the Sensor in G4 or LD Atlas

- Step 1.** If the HVM200 is not already powered on, press the power button once. The Power LED turns blue.
- Step 2.** Connect the HVM200 to G4 (or LD Atlas) via USB.
 

**LEARN MORE** For more information on working with G4 tabs and settings, refer to the **G4 LD Utility Software Manual**. In G4, go to **Help** → **Manuals**.
- Step 3.** Navigate to the **Setup Manager** in either G4 or LD Atlas (In Atlas: tap the **menu icon**  and select **Settings**).
- Step 4.** Select the HVM200 from the right-side drop-down menu in G4. In LD Atlas, select the HVM200 from the blue meter drop-down menu near the top.
- Step 5.** Under the meter settings (displaying the meter serial number), select the **Sensor** tab, and then select **Sensor List**. This opens the Sensor List page.

**FIGURE 4-5 The Sensor Tab and Sensor List Page**



- Step 6.** If the accelerometer is TEDS-enabled, **Sensitivity** values automatically display. If the accelerometer is not TEDS-enabled, do the following:
  - a.** Enter the model and serial number of your accelerometer.
  - b.** Enter the sensitivity for the x, y, and z axes.

**TAKE NOTE** Sensor information, including model, serial number, and sensitivity specifications are usually listed on the calibration certificate that comes with an



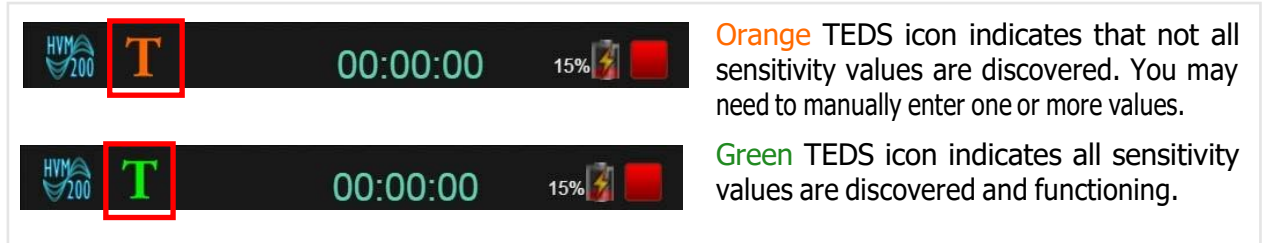
accelerometer. TEDS sensitivity values override any sensitivity values you enter manually.

c. Click or tap **Add**.

**Step 7.** Select the accelerometer when it appears in the list and click or tap **Select**. The sensitivity values automatically appear on the Sensor page.

**Step 8.** Click or tap **Save**. If TEDS is successfully found in the accelerometer, the T icon appears in the top display as shown below.

**FIGURE 4-6 TEDS icon**



## 4.3 Making the Measurement

---

### In this section:

- [4.3.1 Starting or Stopping the Measurement](#)
- [4.3.2 Viewing Live Data](#)

### Before you begin:

- Customize the Setup file as shown in [3.2.2 Creating a Setup File by Using Your Mobile Device](#)
- Make the Setup file active as shown in [3.2.3 Setting the Active Setup File](#)

### 4.3.1 Starting or Stopping the Measurement

---

#### Starting a Measurement

**Step 1.** In LD Atlas or G4, tap or click the **Run button** that appears when the meter is connected.

Starting a new measurement resets the overall measurement data from any previous measurement. If filter settings were changed or the sensor was swapped out, the measurement may be delayed up to 30 seconds to allow the meter to stabilize. This will be indicated by yellow icons shown below in G4 or LD Atlas, and a blinking green LED. See "[LED Indicators](#)" on page A-3.

**FIGURE 4-7 Run Pending Icons**



**TRY THIS** You can also start the measurement manually by pushing the Power button on the HVM200 for at least 1 second after the Status LED is red, as long as the meter is not reading TEDS data from a sensor. For more information, see [2.1.2 Overview of Buttons and Indicators](#)

**FIGURE 4-8 Meter is stopped**



**TRY THIS** If you don't need to monitor the measurement, you can schedule it to begin automatically on the Schedule tab.

## Stopping a Measurement

In LD Atlas or G4, tap or click the **Stop button**.

**FIGURE 4-9 Meter is running a measurement**



## 4.3.2 Viewing Live Data

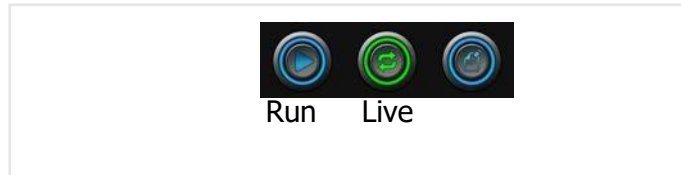
---

### In this section:

- [Live Data Pages](#)
- [Icons and Indicators](#)
- [Annotating the Measurement](#)

**Step 1.** While the meter is stopped, click the red **Stop** button. The green **Live** button appears. To return to stop, press **Live** again.

**FIGURE 4-10 Viewing Live Data & Meter is stopped**



**Step 2.** In the Live View, the LD Atlas app and G4 display current measurement information in **Overall, Summation, X-axis, Y-axis, and Z-axis** pages. Click the **right arrow** or **left arrow icons** to navigate pages. Click the **Zoom** button to enlarge the displayed data.

**Step 3.** (Optional) You may also annotate the measurement before or during. This doesn't require you to stop the measurement.

The following sections provide detail about the information displayed on each page.

## Live Data Pages

### Overall Page

The **Overall** display shows cumulative data for all 3 axes and their summation for the measurement. This data updates once per second (depending connection quality). The overall data provides a digital hold feature for the measurement, capturing the RMS, minimum, and maximum metrics over the measurement. This data is cleared every time a new measurement is started.

**FIGURE 4-11 Overall Data Page**

**a.** Overload Indicator

**b.** Current overall root mean square (RMS) vibration value according to specified units.

**c.** RMS value from the previous second

**d.** Overloaded Indicators

**e.** Summation values:  $\Sigma$  represents the summation of vibration values taken from the X, Y, and Z axes.

**f.** Measurement Duration Clock

**g.** Battery Status

**h.** **RMS:** Root mean square value; **PEAK (PK):** Highest instantaneous value; **MIN:** Lowest value; **MTVV:** Maximum Transient Vibration Value

**i.** Displays values for each axis

**MIN** and **MTVV** are the minimum and maximum whole body and hand/arm values of the vibration signal with a 1 second exponential time weighting. **MIN** and **MAX** are the minimum and maximum general vibration values.

Overall $m/s^2$				
	$a_{RMS}$	$a_{PEAK}$	$a_{MIN}$	MTVV
x	0.6300	30.232	0.0013	10.067
y	0.8127	27.009	0.0005	9.5269
z	0.9194	31.207	0.0014	11.830
$\Sigma$	1.3793	40.525	0.0021	16.542

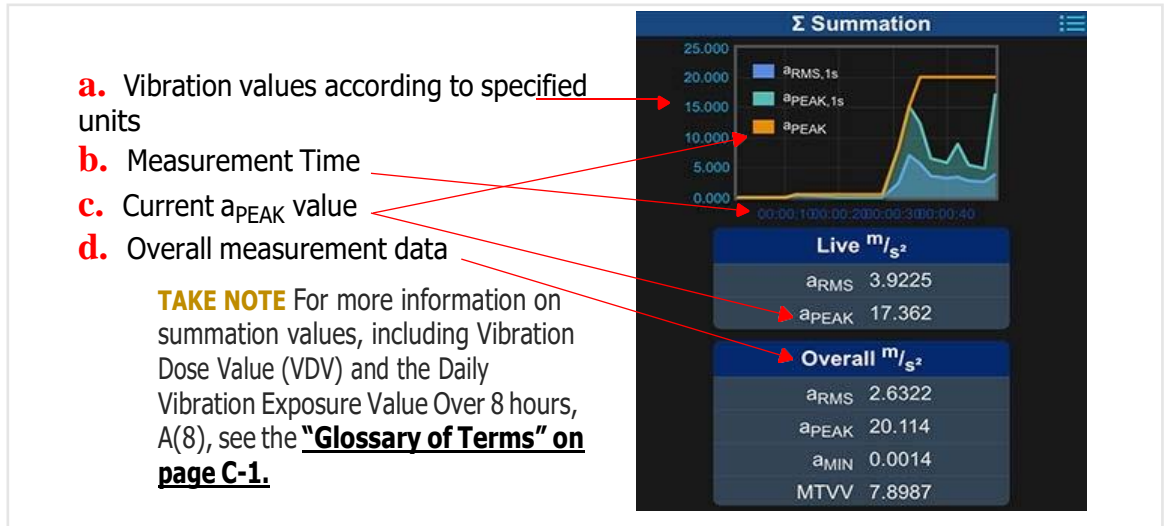
Overall Hand/Arm $m/s^2$					
	A(1)	A(2)	A(4)	A(8)	A(8) Exp(h)
x	0.2652	0.1875	0.1326	0.0938	>24
y	0.3421	0.2419	0.1711	0.1210	>24
z	0.3870	0.2737	0.1935	0.1368	>24
$\Sigma$	0.5807	0.4106	0.2903	0.2053	>24

**LEARN MORE** See more information about how each of these values are calculated in **Appendix C Glossary of Terms**.

### Summation Page

The **Summation** page provides a real-time, graphical representation of the current summed values from all 3 axes.

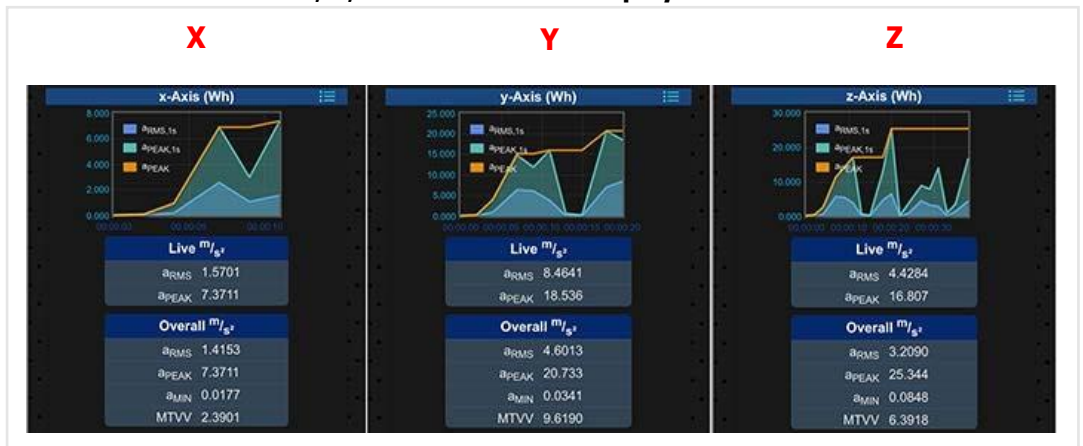
**FIGURE 4-12 Summation Data Display**



### Axes Pages

The Axes pages provide real-time graphical and tabular representations of current and overall values for each axis.

**FIGURE 4-13 X, Y, and Z Axes Data Displays**



### Icons and Indicators

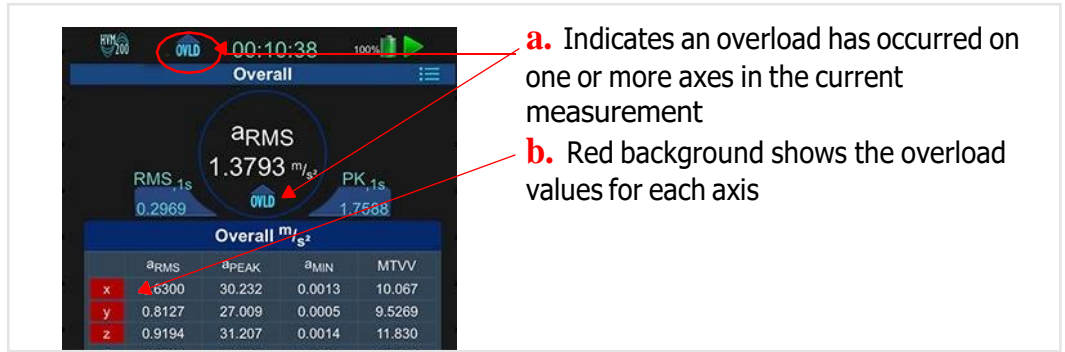
- Overload Indicator
- Under-Range Indicator

### Overload Indicator

An overload occurs when the signal from the accelerometer exceeds the input range of the meter. When this is the current state of the meter, the Status LED is solid yellow. When an overload has occurred during the measurement, the Status LED is blinking green/yellow. Once an overload is latched for the duration of that measurement, and is cleared either on starting a new measurement or after a power cycle.

In G4 or LD Atlas, the Overload icon displays as shown in *Figure 4-14*.

**FIGURE 4-14 Overload Indicators**

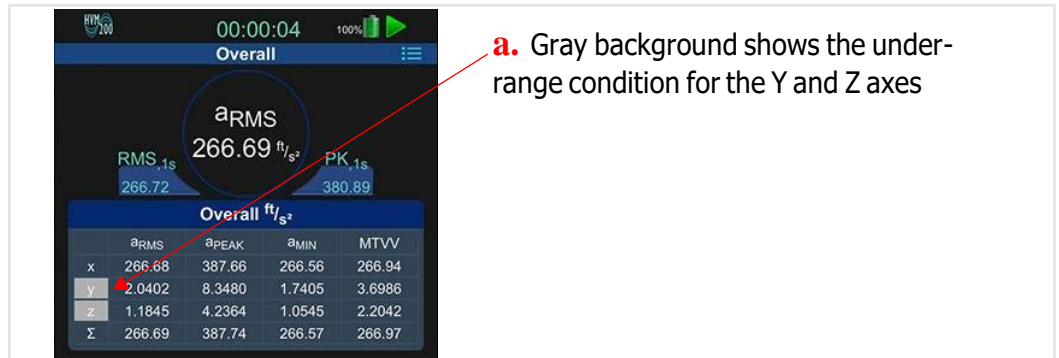


- a.** Indicates an overload has occurred on one or more axes in the current measurement
- b.** Red background shows the overload values for each axis

### Under-Range Indicator


An under-range condition occurs when the signal from the accelerometer is below the input range to the point it cannot be measured accurately.

**FIGURE 4-15 Under-Range Indicators**



- a.** Gray background shows the under-range condition for the Y and Z axes

### Annotating the Measurement

Click the **Annotate button**  and type a note to include with the measurement. You do not need to stop the measurement to annotate. This opens the Annotate window.

**FIGURE 4-16 Annotate Measurement**



**TAKE NOTE** You may include an annotation note before the measurement. This displays as an overall measurement note; only one of these can be applied to the measurement. You can edit the note after the measurement, if needed.

## 4.4 Downloading HVM200 Data

---

You can view and interpret the resulting data by using any of the following actions:

- **Download and view HVM2 files in G4 LD Utility**

G4 LD Utility provides graphing, analysis, and report functionality to provide ease of data interpretation. In case of unwanted artifacts in the data or for 'what if' analysis, you can create exclusion and adjustment bands on the graphical data that will provide a modified summary of the overall metrics.

**TAKE NOTE** You do not need a license to download and view data. Module 11 in the *G4 LD Utility Manual* covers using the HVM200 with G4. To access it, launch G4 on your PC, and go to **Help** → **Manuals** → **G4 LD Utility** → **Module 11**.

- **Download RAW data files to MATLAB, GNU Octave, or a similar program**

**TAKE NOTE** When you create the measurement setup file, specify that you want to store raw data files. This is covered in **3.2.2 Creating a Setup File by Using Your Mobile Device**. For essential information on raw data files, see **4.5 Working with RAW Data Files**.

- **Use a third-party tool that's JSON compatible to view HVM2 files**

**TAKE NOTE** Copy the HVM2 file from the removable SD memory card, and work with it in any JSON-compatible tool.

## 4.5 Working with RAW Data Files

---

The HVM200 analog converter is capable of creating a RAW-format file. This is a binary file that contains raw data samples in a float format for the x, y, and z axes after sensitivity has been applied. The RAW data is not frequency-weighted, not integrated (even if integration is selected), and includes a DC bias. However, all of these factors can be accounted for after the data is parsed.

**LEARN MORE** For more information, see **Table 4.2 Parameters and transfer functions of the frequency weightings (source: ISO 8041)**

The data samples represent scaled ADC samples in  $m/s^2$  with a DC bias. Each sample contains 12 bytes in the following format:

**Table 4.1 RAW Data File Sample Structure**

Byte	0	1	2	3	4	5	6	7	8	9	10	11
Definition	X Axis Sample			Y Axis Sample			Z Axis Sample					

The byte order within each float is little-endian.

You can create RAW-format data files with each measurement if you checked **Store Raw Data** in the measurement setup. For more information, see **3.2.2 Creating a Setup File by Using Your Mobile Device**. While the HVM200 is connected to G4, you can download RAW files from the Files view (see *Figure 4-17*).

**FIGURE 4-17 Raw Data File**



## 4.5.1 Using the Raw Data Script

You will need MATLAB, GNU Octave, or similar program to work with RAW format files after downloading. The scripts in the following sections enable you to parse the data. Consider the following items when using them:

- You must adjust the file name to match the file name of your RAW file.
- Remember to remove the DC bias from data.
- After the file is parsed, you can adjust the weighting filters for hand/arm or whole body vibration purposes. The script for this is provided in section **4.5.2 Weighting Filters for Raw Data**.
- If using GNU Octave, the bi-linear function takes Period instead of Frequency as a parameter. Replace "fs" with "1/fs" throughout.

```
% Example Matlab / GNU Octave code for parsing HVM200 raw data format
close all; clear all; clc;
% Number of Samples to read
Sample_Rate = 7161.45833;% Hz (Hard wired sample rate)
Sample_Time = 10; %second
num_samples_to_read = Sample_Rate*Sample_Time;

% Open file, Read, Close
% filename = 'HVM_SERIAL_NUMBER_BASENAME_DATESTAMP.00.raw';
filename = 'HVM_0000056_HVMD_151216_180801.00.raw';
rawsavefilename = 'HVM_0000056';
filteredsavefilename = 'HVMFilt_0000056';
FID = fopen(filename,'r');
A = fread(FID,[num_samples_to_read*3],'float');
fclose(FID);

% Build Axis data
axis_counter = 1;
x_axis = zeros(1,floor(num_samples_to_read));
y_axis = zeros(1,floor(num_samples_to_read));
z_axis = zeros(1,floor(num_samples_to_read));
x_axis = A(1:3:end);
```

```

y_axis = A(2:3:end);
z_axis = A(3:3:end);
%% Remove DC bias from data (optional)
x_axis = x_axis - mean(x_axis);
y_axis = y_axis - mean(y_axis);
z_axis = z_axis - mean(z_axis);

%% Plot
figure(1);
plot(x_axis, '-b');
hold on;
plot(y_axis, '-r');
plot(z_axis, '-k');
hold off;
legend('x', 'y', 'z');
title('HVM200 Data');

save(rawsavefilename, 'x_axis', 'y_axis', 'z_axis', 'Sample_Rate', 'Sample_Time');

%% Further processing through ISO 8041 Wk filter
x_axis_filt = isofilwk(x_axis, Sample_Rate);
y_axis_filt = isofilwk(y_axis, Sample_Rate);
z_axis_filt = isofilwk(z_axis, Sample_Rate);
figure(2);
plot(x_axis_filt, '-b');
hold on;
plot(y_axis_filt, '-r');
plot(z_axis_filt, '-k');
hold off;
title('HVM200 Data with Wk filter');
legend('x', 'y', 'z');

save(filteredsavefilename, 'x_axis_filt', 'y_axis_filt', 'z_axis_filt', 'Sample_
Rate', 'Sample_Time');

```

## 4.5.2 Weighting Filters for Raw Data

---

You can use the "isofilwk()" script shown here to adjust the raw data file for hand arm or whole body vibrations. Locate your desired parameters for other weighting filters in *Table 4.2* (below), then replace the corresponding values in the "isofilwk()" script.

The "isofilwk()" script is sample code taken from the ISO 8041 standard.



```

isofilwk() Sample Code (ISO 8041 standard)
function y = isofilwk(x, fs)

% ISOFILWK
% Filter ISO 8041 Wk
%     y = isofilwk(x,fs)
%     y output signal, acceleration
%     x input signal, acceleration
%     fs sampling frequency Hz
%     bilinear transformation algorithm is used
f1 = 0.4;
f2 = 100;
f3 = 12.5;
f4 = 12.5;
Q4 = 0.63;
f5 = 2.37;
Q5 = 0.91;
f6 = 3.35;
Q6 = 0.91;

% Note that in the function "butter" the variables Q1 and Q2 are
% effectively set to equal to 1/sqrt(2), therefore they don't need
% to be explicitly set here.

w3 = 2*pi*f3;
w4 = 2*pi*f4;
w5 = 2*pi*f5;
w6 = 2*pi*f6;

nyq = fs/2; % Nyquist frequency

% determine parameters for band limiting high pass and low pass
[b1,a1] = butter (2,f1/nyq, 'high' ); % High pass
[b2,a2] = butter (2,f2/nyq); % Low pass

% determine parameters for a-v transition
B3 = [1/w3 1];
A3 = [1/w4/w4 1/Q4/w4 1];
[b3,a3] = bilinear (B3, A3, fs);

% determine parameters for upward step
B4 = [1/w5/w5 1/Q5/w5 1]*w5*w5/w6/w6;

```

```
A4 = [1/w6/w6 1/Q6/w6 1];  
[b4,a4] = bilinear (B4, A4, fs);  
  
% Apply filter to input signal vector x (output to signal vector y)  
y = filter (b2, a2, x); % Apply low-pass band limiting  
y = filter (b1, a1, y); % Apply high-pass band limiting  
y = filter (b3, a3, y); % Apply a-v transition  
y = filter (b4, a4, y); % Apply upward step  
  
end
```

**Table 4.2 Parameters and transfer functions of the frequency weightings (source: ISO 8041)**

Weighting	Band-limiting				a-v-transition			Upward step				Gain
	$f_1$	$Q_1$	$f_2$	$Q_2$	$f_3$	$f_4$	$Q_4$	$f_5$	$Q_5$	$f_6$	$Q_6$	K
	Hz		Hz		Hz	Hz		Hz		Hz		
$W_b$	0.4	$1/\sqrt{2}$	100	$1/\sqrt{2}$	16	16	0.55	2.5	0.9	4	0.95	1.024
$W_c$	0.4	$1/\sqrt{2}$	100	$1/\sqrt{2}$	8	8	0.63	$\infty$	1	$\infty$	1	1
$W_d$	0.4	$1/\sqrt{2}$	100	$1/\sqrt{2}$	2	2	0.63	$\infty$	1	$\infty$	1	1
$W_e$	0.4	$1/\sqrt{2}$	100	$1/\sqrt{2}$	1	1	0.63	$\infty$	1	$\infty$	1	1
$W_f$	0.08	$1/\sqrt{2}$	0.63	$1/\sqrt{2}$	$\infty$	0.25	0.86	0.0625	0.80	0.10	0.80	1
$W_h$	$10^{8/10}$	$1/\sqrt{2}$	$10^{31/10}$	$1/\sqrt{2}$	$100/(2\pi)$	$100/(2\pi)$	0.64	$\infty$	1	$\infty$	1	1
$W_j$	0.4	$1/\sqrt{2}$	100	$1/\sqrt{2}$	$\infty$	$\infty$	1	3.75	0.91	5.32	0.91	1
$W_k$	0.4	$1/\sqrt{2}$	100	$1/\sqrt{2}$	12.5	12.5	0.63	2.37	0.91	3.35	0.91	1
$W_m$	$10^{-0.1}$	$1/\sqrt{2}$	100	$1/\sqrt{2}$	$1/(0.028 \times 2\pi)$	$1/(0.028 \times 2\pi)$	0.5	$\infty$	1	$\infty$	1	1

**NOTE 1** For weighting  $W_b$ , Table A.1 of ISO 2631-4:2001 rounds the value of parameter  $Q_1$  to 2 decimal places. The parameter specified here is the exact value.

**NOTE 2** For weighting  $W_h$ , Table A.1 of ISO 5349-1:2001 rounds the values of parameters  $f_1$ ,  $f_2$ ,  $f_3$  and  $f_4$  to 5 significant figures and parameter  $Q_1$  to 2 decimal places. The parameters specified here are the exact values.

# Chapter **5** Settings and Features Reference

This module provides instructions for setting and disabling features, upgrading the HVM200, and troubleshooting when necessary.

## In this module:

5.1	Setting/Syncing Meter Time and Date	40
5.2	Enabling/Disabling the HVM200 WiFi Signal	42
5.3	Upgrading Firmware or Options	43
5.4	Troubleshooting HVM200 External Memory	44

## 5.1 Setting/Syncing Meter Time and Date


---

The HVM200 has a time feature that allows the meter's internal clock to be either manually set or synced with your PC or mobile device.

### Setting/Syncing Time in G4 LD Utility

#### Before you begin:

- Make sure the meter is powered on.
- Launch G4 and connect the HVM200 meter. For more information, see [2.5 Connecting the HVM200 to G4](#).
- Be sure you're in the Active setting. You're in Active setting if you can see the **Time** tab in G4.

- Step 1.** In G4, open the meter tab and go to the  **Manager** view, **Maintenance** page.
- Step 2.** Click **Sync PC and Meter Clocks**.
- Step 3.** Select **Set** to use the PC clock as the new time for the meter. If you choose to deselect this option, you can set the date and time manually, as shown in the next section.

**FIGURE 5-1 Date and Time**



## Setting the Meter Time Manually in G4

If desired, complete these steps in G4 instead of automatic time sync.

**Step 1.** Click in the **Time** field and enter the time.


**Step 2.** Click in the **Date** field and enter the date.

**Step 3.** Click **Set Time**.

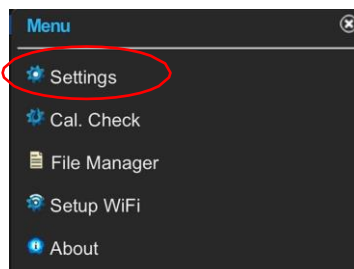
## Setting/Syncing Time in LD Atlas

### Before you begin:

- Power on the HVM200.
- Launch the app and connect the HVM200 meter. For more information, see [2.4 Connecting HVM200 to a Mobile Device](#).

**Step 1.** In the app, select your meter in the meter list, then tap  **Menu** → **Settings**.

**FIGURE 5-2 HVM200 Menu**



**Step 2.** In the Setup Manager, tap the **Setup menu** , and choose the **Time** page.

**FIGURE 5-3 HVM200 Settings, Time Page**



**Step 3.** Tap **Sync Time** to sync the time on the meter with the time on your mobile device.

## **5.2 Enabling/Disabling the HVM200 WiFi Signal**

---

### **5.2.1 Disabling the HVM200 WiFi Signal**

---

This section shows how to disable the WiFi signal on the HVM200 meter. Once complete, you can only re-enable WiFi from G4 with the meter connected via USB.

**Step 1.** Launch LD Atlas app or the G4 LD Utility Live View.

**Step 2.** Click the menu icon , and select **Setup WiFi** from the menu that appears. This opens the Network page.

**Step 3.** Click the **power icon**  in the top left.

**Step 4.** The app displays a WiFi Alert. Select **Confirm** to continue. WiFi is now disabled.


### **5.2.2 Enabling the HVM200 WiFi Signal**

---

To enable the WiFi signal on the HVM200, complete the following steps.

#### **Before you begin:**

- Launch G4 on your PC.
- Connect the HVM200 via USB cable to your PC. For help with this, see, "Connecting the HVM200 to G4 LD Utility via USB". The USB connection is required for this process.

- Step 1.** In G4, go to the **Setup WiFi** page.
  - Step 2.** Click the **red power icon**  in the top left.
  - Step 3.** G4 displays a WiFi Alert. Click **Confirm** to continue.
  - Step 4.** Select the **Reboot** button, then click **Confirm** in the pop-up window to continue.
- TAKE NOTE** You can also press and hold the power button on the meter.
- Step 5.** Wait 30 seconds.
  - Step 6.** Reconnect your meter to G4 or the app.

## 5.3 Upgrading Firmware or Options

---

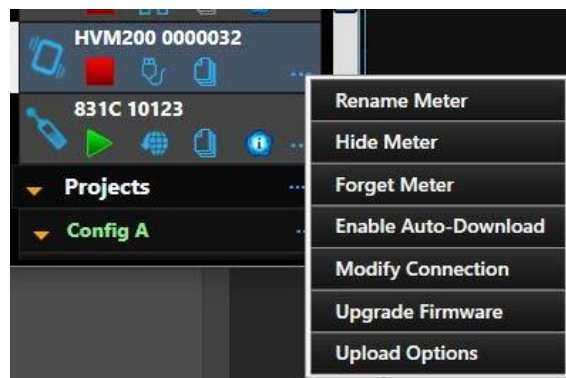
The process for upgrading the HVM200 firmware file or options file is the same. To upgrade the options file, select the "Options" item each time "firmware" is mentioned in this section.

### **Before you begin:**

- Launch G4 on your PC.
- Power on and connect the HVM200 via USB cable to your PC. For help with this, see, **2.5.1 Connecting the HVM200 to G4 LD Utility via USB**. The USB connection is required for this process.
- Close any open HVM meter tabs.

- Step 1.** In G4, open the Meter Panel Menu by clicking the three dots on the HVM200 in the Meters Panel.

**FIGURE 5-4 Meter Panel Menu=**



- Step 2.** Select Upgrade Firmware (or Upload Options)
- Step 3.** Select the checkbox in-line with **Firmware** or **Options**.

**Step 4.** Click **Choose Firmware File** or **Choose Options File**.

**FIGURE 5-5 Upgrade Firmware or Options**



**Step 5.** In the File Explorer window that opens, open the available firmware or options file.

**Step 6.** In the G4 Upgrade window, choose **Upload Firmware** or **Upload Options**. G4 will show an upgrade progress overlaid on the meter panel, and once completed will display a success message.

## **5.4 Troubleshooting HVM200 External Memory**

---

The HVM200 in G4 has two external memory error notices:

- HVM200 Cannot Access External Memory Storage
- External Memory Card File System is Corrupted

These errors most often occur when the SD card is removed while the meter is powered on. If this is the case, reinsert the SD card to allow the meter to complete the interrupted process.

If the problem persists, or if the HVM200 in G4 indicates that the file system is corrupted, power the meter off, insert the SD card into a PC or card reader, and download important files.

Next, use the Windows utility to repair or reformat the SD card file system before reinserting the SD card into the HVM200.

**CAUTION** Be sure to only insert or remove the SD card when the meter is powered off. Accessing the SD card while the meter is powered increases the risk of internal damage to the meter due to electrostatic discharge (ESD).



# Appendix **A** Specifications

The following specifications are subject to change without notice.

## A.1 General Characteristics

### Measurement modes

- Hand-arm, Whole-body, Vibration

### Measurement Units

- $m/s^2$ ,  $cm/s^2$ ,  $\mu m/s^2$ ,  $ft/s^2$ ,  $in/s^2$ , g, dB

**TABLE A.1 Metrics by mode:**

Vibration	RMS, Peak, Min, Max (x, y, z & $\Sigma$ )
Hand-arm	RMS, Peak, Min, MTVV, A(8) (x, y, z & $\Sigma$ )
Whole-body	RMS, Peak, Min, MTVV, A(8) Act, A(8) Exp, EP VDV (x, y, z & $\Sigma$ )

### Time History (Logging)

- Store interval (user-selected):  
1, 2, 5, 10, 20, 30 sec;  
1, 2, 5, 20, 30 min; 1 hr
- Stored values:  
RMS and Peak for x, y, and z axes and for  $\Sigma$ .

### Run Modes

- Manual: Run/stop with app or meter button
- Timed: Start at time specified in setup
- Delayed: Start after delay specified in setup of 5, 10, 20, 30, or 60 seconds

### Clock/Calendar

- Clock format is 24 hours: hh:mm:ss
- Run-time resolution: 1 second
- Typical clock retention during battery change is 5 minutes

### Time of Day Drift

- Worst case:  
6.91 seconds per day(-10 °C to + 50 °C)

### Effects of Temperature and Humidity

- Operating temperature:  
14°F to 122°F (-10 °C to 50 °C)
- The RMS level of the HVM200 varies up to  $\pm 1\%$  when exposed to temperatures of - 10 °C to 50 °C and relative humidity (RH) 20 to 90% (non-condensing).
- Tested at 159.4 Hz and 9.81  $m/s^2$ .

### WiFi Connectivity

- HVM200 WiFi connectivity follows IEEE 802.11b/g/n protocol.

### Radio Frequency Emissions

- The HVM200 conforms to FCC, IC, and CISPR 11 emissions limits. The meter connected over WiFi while charging over USB produces the greatest emissions.

### Effects of Electrostatic Discharge (ESD)

- This instrument is not adversely affected by electrostatic discharge under normal operating conditions and within normal human static discharge limits of IEC 61000-4-2:2008,  $\pm 4$ kV contact discharges and  $\pm 8$  kV air discharges. Care must be taken when replacing the battery and the microSD card, the meter should be powered off before opening the battery door.

### Effects of Magnetic Fields

- Complete instrument RMS level varies up to  $\pm 1.4\%$  when exposed to an 80 A/m, 60 Hz magnetic field (worst case orientation). The complete instrument is defined as the HVM200 meter, CBL217-01, and SEN041F.

## Effects of Mechanical Vibrations

- Complete instrument RMS level varies up to  $\pm 0.4\%$  when exposed to mechanical vibrations of  $30 \text{ m/s}^2$  at  $79.58 \text{ Hz}$  (worst-case orientation).

## AC Power and Radio Frequency Susceptibility

- Tests were performed to evaluate RF susceptibility. These tests were completed according to ISO8041. The HVM200 was configured to vibration mode with the widest bandwidth selected (Fb). The meter was configured with a non-coiled 16-inch accelerometer cable and a  $10 \text{ mV/g}$  sensor (SEN021F). In this configuration, the maximum induced noise by the RF field was  $<2.5 \text{ m/s}^2$  across all frequencies and orientations. Minimum immunity is seen with longer cables coiled like a solenoid such that the RF field is oriented to pass through the coil.

## Stabilization Time

- 30 seconds after power up or settings change  
Note: Measurements with integration settings require up to one minute additional stabilization time before initiating (the Power LED may display a solid green color during this additional stabilization time).
- For significant changes in environmental conditions (i.e. temperature changes  $> 5^\circ \text{ C}$ ), allow the meter and sensor 30 minutes to acclimate to the new conditions before beginning a measurement.

## Data Storage

- Removable micro SD memory card up to 32 GB.
- 2 GB file size limit. Files are truncated at 2 GB. No limit to number of files or setups.
- Data and settings are stored in non-volatile memory
- Swapping limitation: Device must be off while replacing Micro SD card or battery.

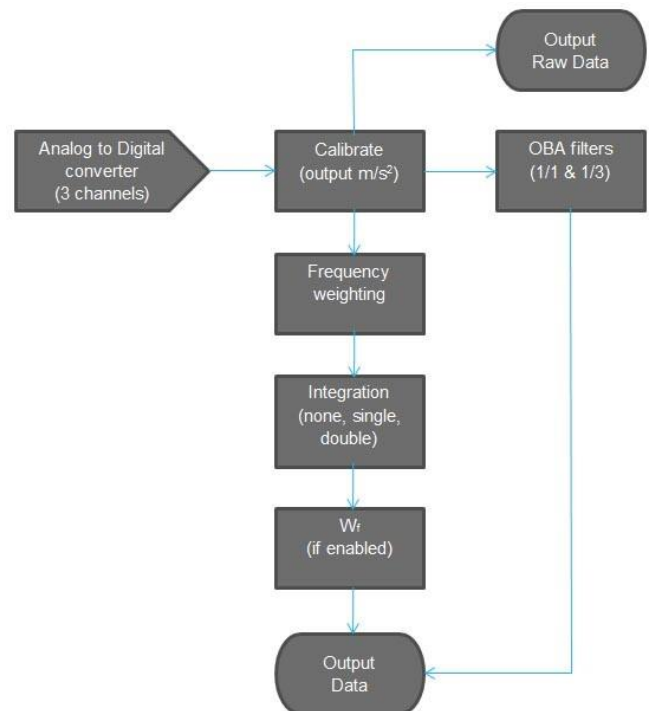
## Transducer Electronic Data Sheets (TEDS) Support

- Chips supported by HVM200:  
DS2430 and DS2431
- Versions supported:  
0.9 (only DS2430 chip) and 1.0
- Templates supported:  
0 (version 0.9), 25 (version 1.0)

## Data Flow Characteristics

Data flow is characterized by the chart shown in .

**FIGURE A-1 Data Flow Block Diagram**



## A.2 Physical Characteristics

---

### Dimensions/Weight

- Length: 4.6 inches (11.8 cm)
- Width: 2.6 inches (6.7 cm)
- Depth: 0.7 inches (1.8 cm)
- Weight: 4.6 ounces (130 grams) - including battery
- Ingress Protection Rating: IP42

### Communication Interface

- USB 2.0 Hi-Speed
- WiFi 802.11 b/g/n with WPA and WPA2 security

### Connections

- Micro-B USB cable (Communication and power)
- 1/4-28, 4-pin, 3-channel sensor connector

## A.3 Operational Characteristics

---

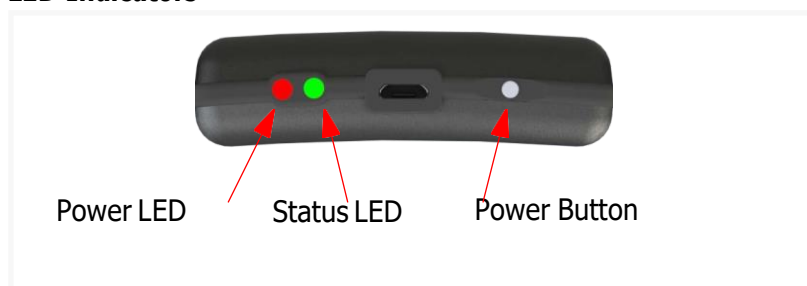
### HVM200 Memory

The HVM200 has two memory cards: 2 GB internal and external SD memory. If the external memory card is removed or not working, the HVM200 automatically switches to internal memory storage. For troubleshooting recommendations, see [5.4 "Troubleshooting HVM200 External Memory" on page 44](#).







### LED Indicators

The following tables shows HVM200 LED indications, states, and additional information.






**FIGURE A-2 HVM200 LED Indicators**



**TABLE A.2 HVM200 Power LED (Left) Indications**

Indication	State	Additional Information
	<b>System Warning</b>	Click the Warning Icon on the G4 LD Utility Live View. The "About This Meter" information shows if there is a sensor/cable connection error, battery connection error, or SD memory card error. To avoid system errors, do not hot swap SD memory cards.   G4 Live View Warning Icon
 (Blinking)	<b>Battery Low</b>	Charge the HVM200 via USB from your computer or from the PSA035 power supply. If not charged, the HVM200 will shut down when the remaining battery life approaches the threshold for safe shut down at 5% battery. If the HVM200 shuts down mid-measurement, the file is truncated and G4 LD Utility may not be able to display summary information for the file.
	<b>Battery Charging</b>	Allow the battery to charge fully to maximize overall battery life.
	<b>Battery Charged</b>	Estimated Battery Runtime is shown on the meter About Page
	<b>Power On</b>	Power On is displayed both on start up and shut down. When turning on the HVM200, press the power button for about one second until the blue LED is displayed. When shutting down, press the power button until the blue LED is displayed and the Status LED is dark. Power On is also displayed when the HVM200 is running on battery power (not simultaneously charging through USB connection).

**TABLE A.3 HVM200 Status LED (Right) Indications**

Status LED		
Indication	State	Additional Information
	<b>Measurement Stopped</b>	The HVM200 is not running a measurement. The red LED will periodically blink while in this state.
	<b>Measurement Running</b>	The HVM200 is in the process of taking a measurement. The green LED will periodically blink while in this state.
 (Blinking)	<b>Measurement Run Pending</b>	The HVM200 is stabilizing for an impending measurement, which may last up to 60 seconds, or is awaiting a delayed start set from the scheduling tab. The green LED will constantly blink while in this state.
	<b>Overload</b>	A signal from the accelerometer is currently exceeding the calibrated input range of the HVM200.
 (Blinking)	<b>Overloaded</b>	An overload has occurred in this measurement.

**TABLE A.4 Power Button Functions**

<b>Power Button Functions</b>	
<b>Action</b>	<b>Press Power Button</b>
Turn on power	At least one second until Power LED is blue
Turn off power	Until Power and Status LEDs are blue. Meter will power off after a few seconds
Start or stop toggle for manual measurement	After turning on meter, less than three seconds
Shut down (if unresponsive)	At least 16 seconds

## **A.4 Electrical Characteristics**

---

### **Power Consumption**

- USB Power: 130 mA in station mode; 180 mA in access point mode
- Battery run time:
  - Up to 9 hours
  - Up to 12 hours (Wi-Fi disconnected or disabled)

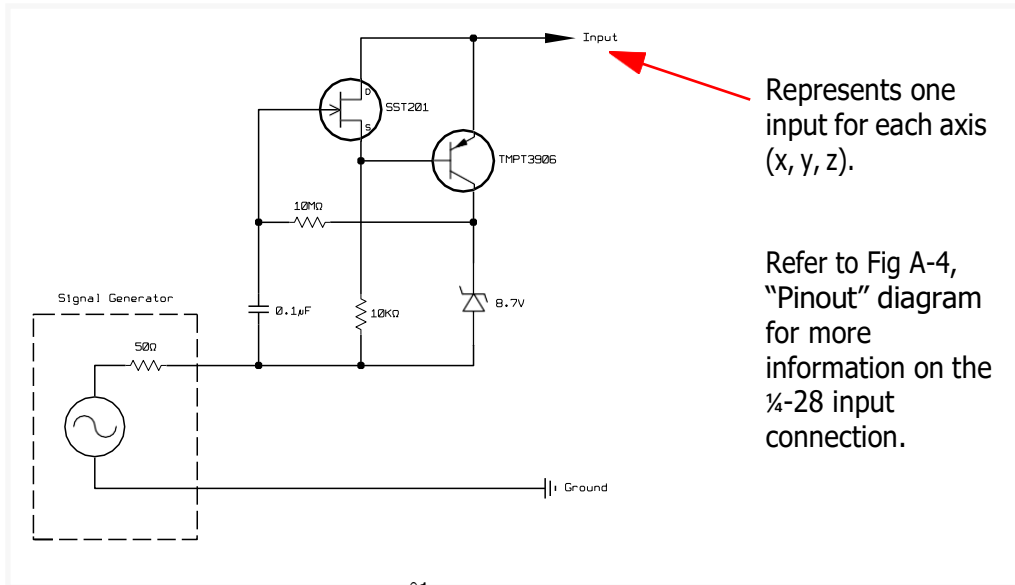
### **Power Supply**

- User replaceable rechargeable lithium-ion battery, voltage range 3.4 V- 4.2 V
- Charge time: 3.5 hours with Larson Davis PSA035 power supply
- External Power:
  - USB Type A to Micro-B USB cable, 3 ft (1 m)
  - Larson Davis Power Supply PSA035 (universal 100-240 VAC to 5 V USB power adapter)

## Electrical Testing

During electrical testing, the following circuit was used:

**FIGURE A-3 Circuit for electrical testing**



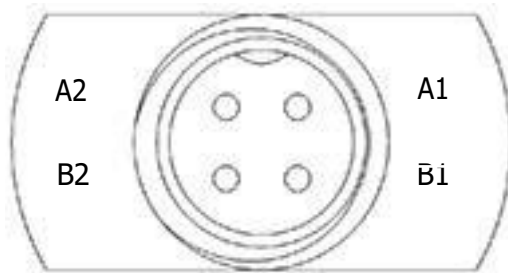
Circuit to Inject Electrical Signal into HVM200 ICP<sup>®1</sup> Inputs

## Input

- Input type: ICP, IEPE, or CCP
- Excitation current: 2 mA
- Input connector: 1/4-28 4-pin male (the input connection is also the transducer connection)
- Measurement input voltage range: 1.8 to 16 Vdc
- Measurement AC reference bias voltage: 9 Vdc
- Absolute voltage range (min to max): 0 to 28 V
- Bandwidth: 0.4 Hz to 3000 Hz
- Range: Single range
- Sample rate: 7161.45833 Hz
- Maximum recommended cable length: 5 ft

1. ICP is a registered trademark of PCB Piezotronics, Inc.

**FIGURE A-4 Pinout**



<b>Pin</b>	<b>Signal</b>
A1	GND
A2	X Axis
B1	Y Axis
B2	Z Axis

### **Anti-alias Filter Performance**

The anti-alias filter attenuates all frequencies above the stop band frequency at 100 dB.

**Sample Rate:** 7161.45833 Hz

**Stop Band Frequency:** 3917.318 Hz

**Stop Band Rejection:** 100 dB

**Pass Band -3db Frequency:** 3509.115

**Pass Band Frequency:** 3244.141

## A.5 Reference Values

The following values represent the primary frequencies and amplitudes at which weighting filters are specified and tested.

**TABLE A.5 Operating Mode Reference Values**

Operating Mode	Frequency Weighting	Reference Frequency	Reference Amplitude
Vibration	Fa (0.4 Hz to 100 Hz) Fb (0.4 Hz to 1250 Hz) Fc (6.3 Hz to 1250 Hz)	50 rad/s (7.958 Hz) 500 rad/s (79.58 Hz) 500 rad/s (79.58 Hz)	10 m/s <sup>2</sup> 10 m/s <sup>2</sup> 10 m/s <sup>2</sup>
Hand Arm	Wh	500 rad/s (79.58 Hz)	10 m/s <sup>2</sup>
Whole Body	Wm	100 rad/s (15.915 Hz)	1.0 m/s <sup>2</sup>
	Wb		1.0 m/s <sup>2</sup>
	Wc		1.0 m/s <sup>2</sup>
	Wd		1.0 m/s <sup>2</sup>
	We		1.0 m/s <sup>2</sup>
	Wj		1.0 m/s <sup>2</sup>
	Wk	1.0 m/s <sup>2</sup>	
	Wf (Severity)	2.5 rad/s (0.3979 Hz)	0.1m/s <sup>2</sup>

## A.6 Measurement Ranges

The following table shows the HVM200 dynamic and linearity ranges in root-mean square values. (Peak values are 1.414 times higher.)

**TABLE A.6**

Frequency Weighting	Noise Floor (typical mV)	Lower Limit (Under-range mV)	Lower Limit Linearity Range (typical mV)	Lower Limit Linearity Range (maximum mV)	Upper Limit (Overload V)
Fa	0.028	0.204	0.092	0.178	5.01
Fb	0.046	0.232	0.133	0.176	5.01
Fc	0.041	0.205	0.116	0.152	5.01
Wb	0.016	0.167	0.073	0.137	5.01
Wc	0.021	0.184	0.089	0.150	5.01
Wd	0.014	0.181	0.072	0.175	5.01
We	0.012	0.193	0.073	0.161	5.01
Wf	0.009	0.185	0.100	0.147	5.01
Wh	0.014	0.087	0.042	0.090	5.01
Wj	0.023	0.167	0.077	0.151	5.01



Frequency Weighting	Noise Floor (typical mV)	Lower Limit (Under-range mV)	Lower Limit Linearity Range (typical mV)	Lower Limit Linearity Range (maximum mV)	Upper Limit (Overload V)
Wk	0.018	0.144	0.073	0.121	5.01
Wm	0.017	0.103	0.060	0.077	5.01

## A.7 Frequency Weighting Curves

The following graphs show frequency weighting curves for the HVM200. Choosing the appropriate weighting for your measurement is vital to achieve the most accurate results. For details on this, see this article from LarsonDavis.com: ["Which Whole Body Vibration Weighting Should I Use?"](#)

FIGURE A-5

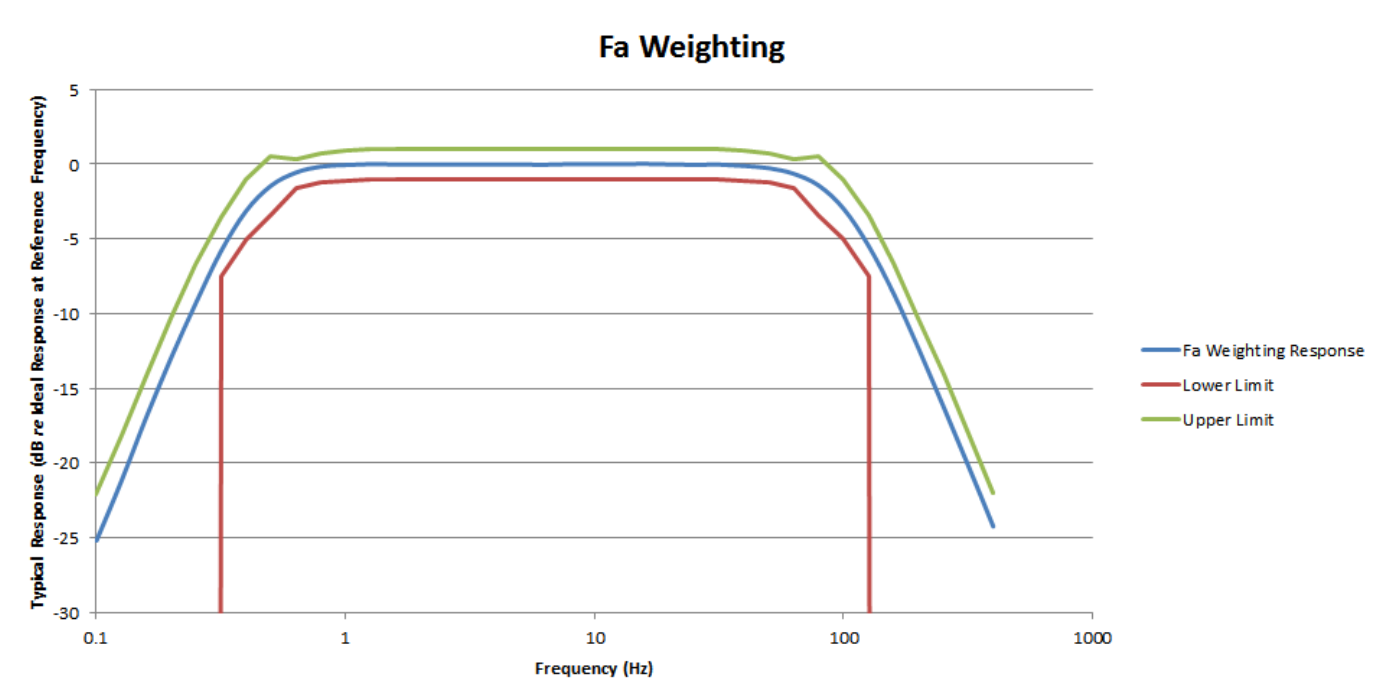


FIGURE A-6

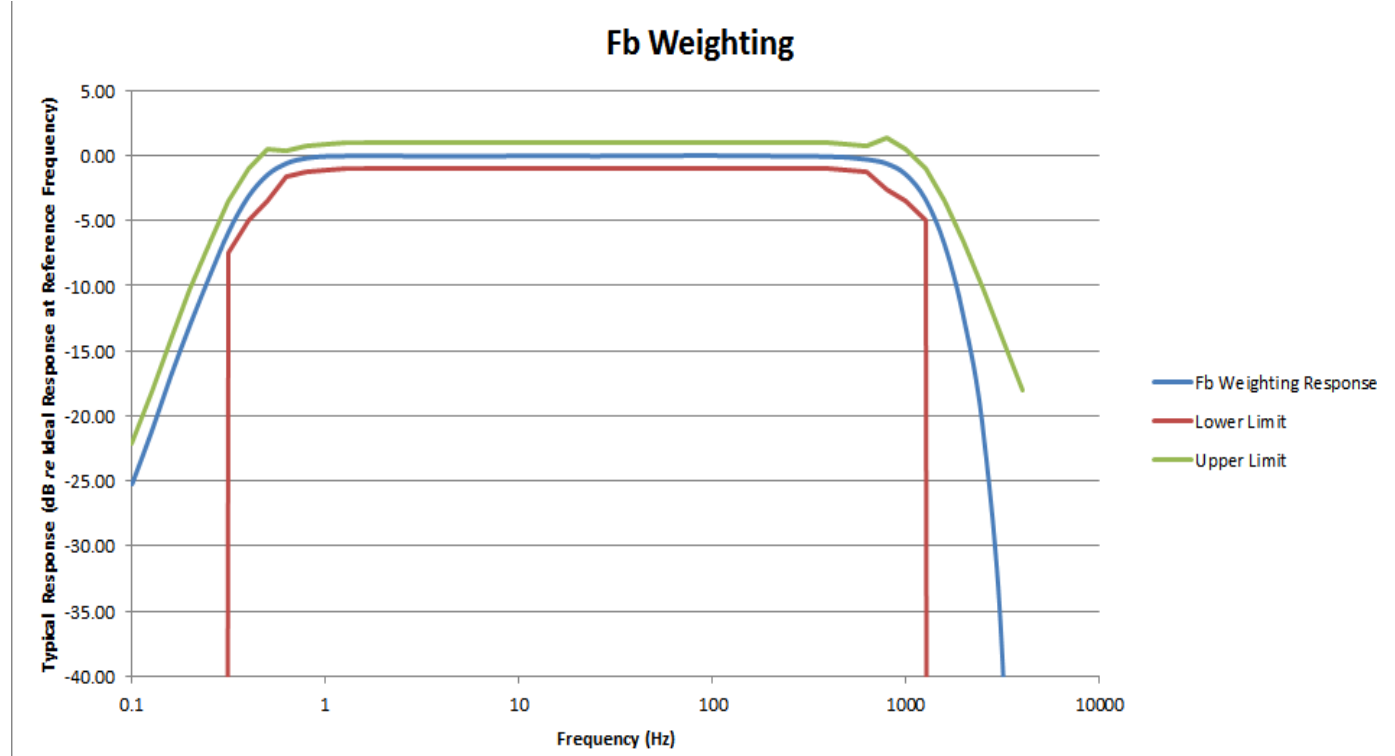
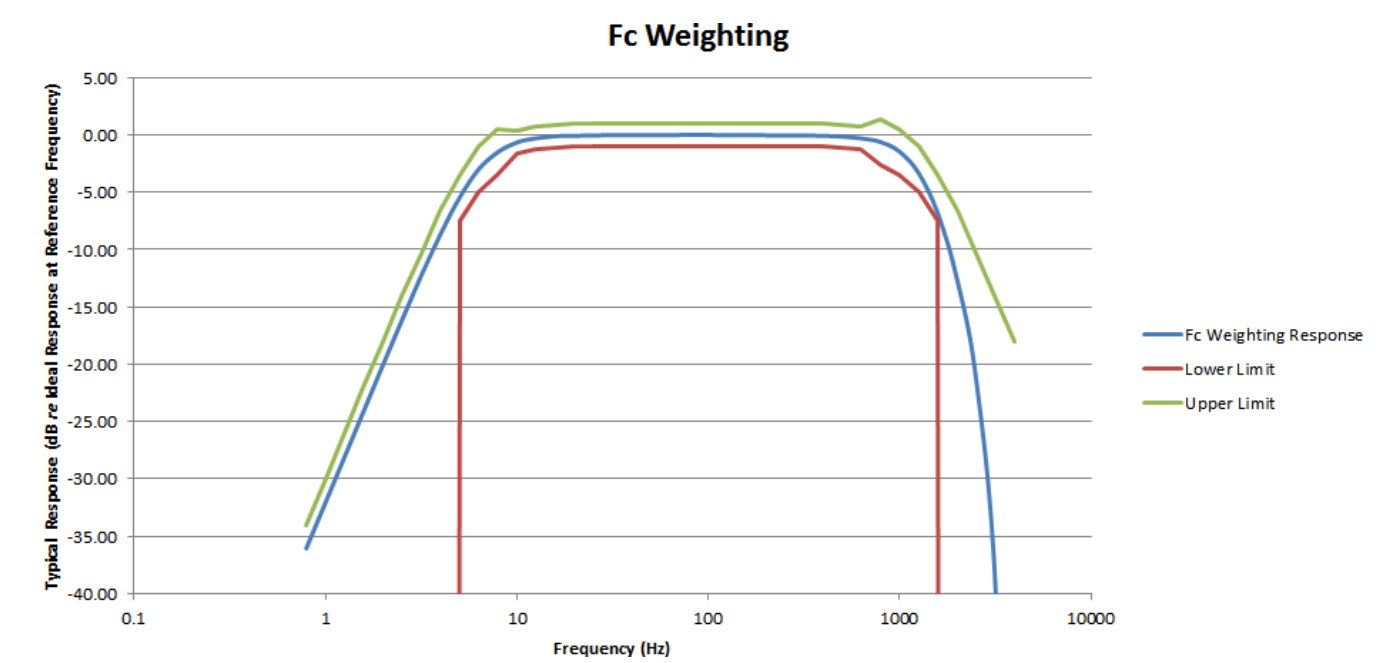
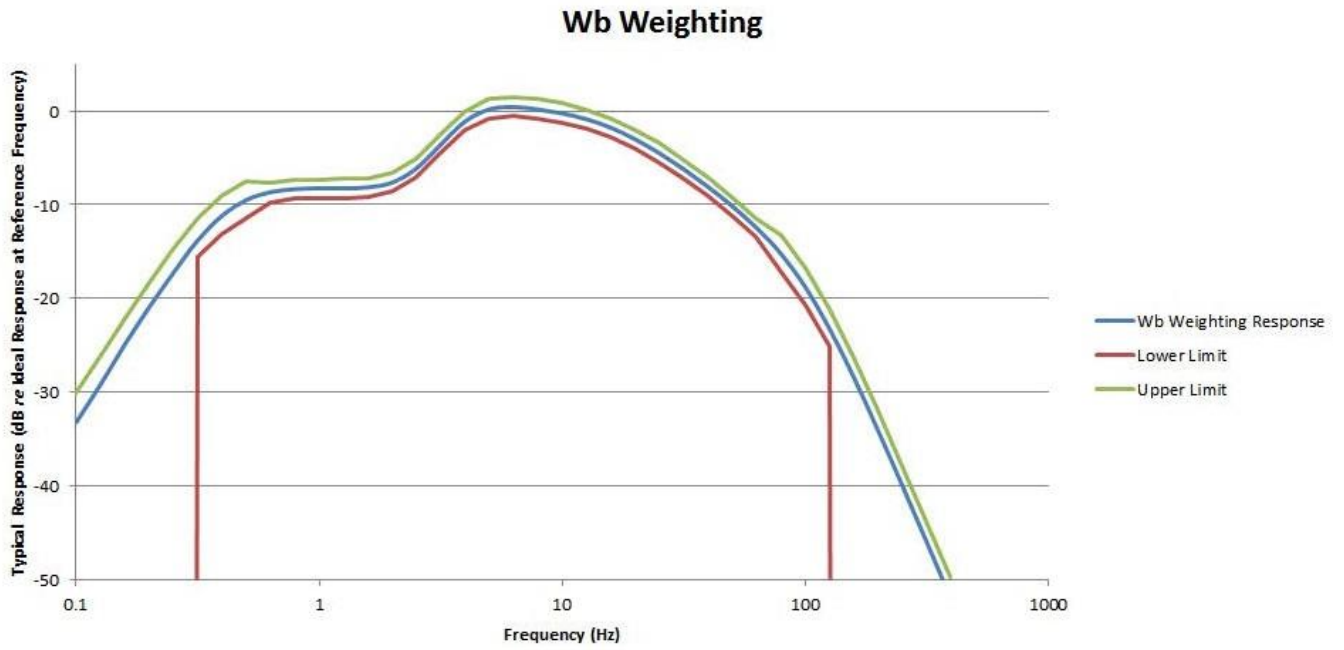


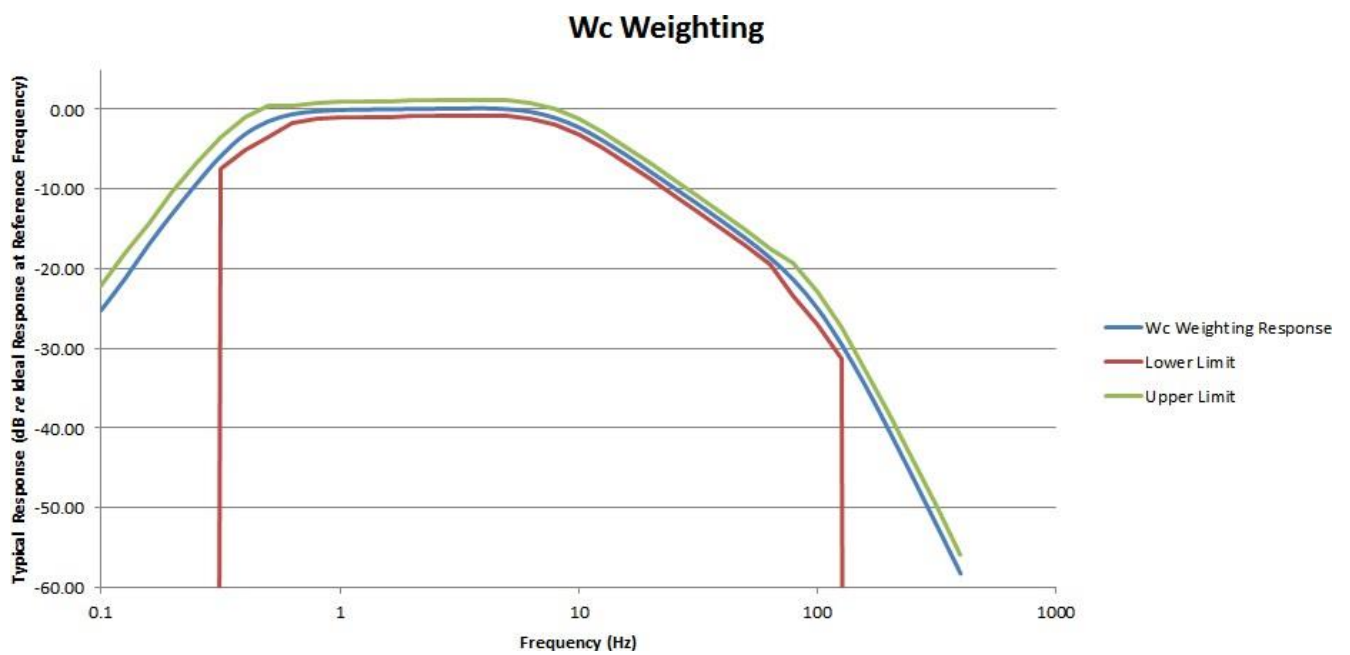
FIGURE A-7



**FIGURE A-8**

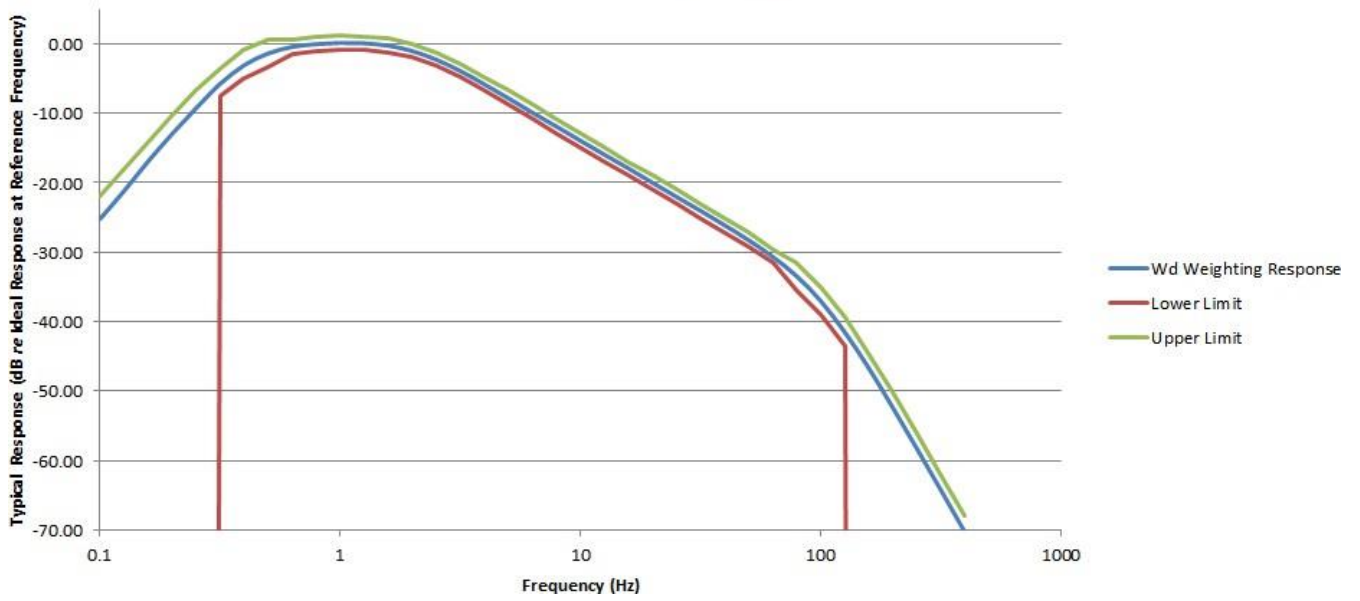


**FIGURE A-9**



**FIGURE A-10**

**Wd Weighting**



**FIGURE A-11**

**We Weighting**

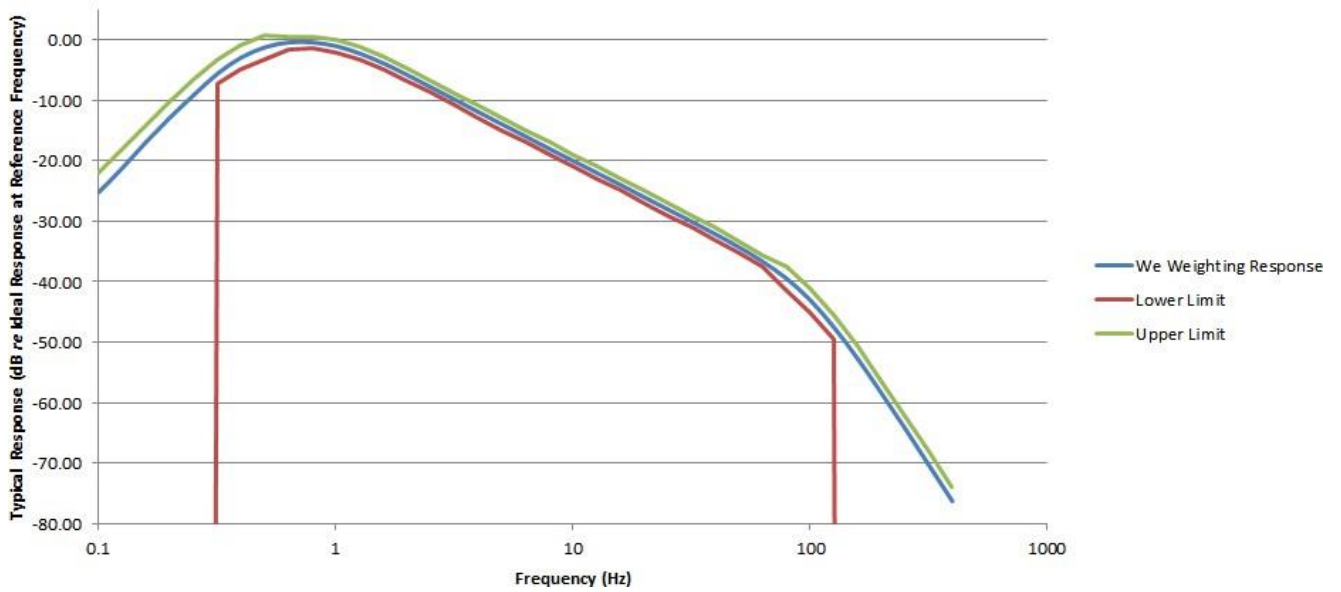


FIGURE A-12

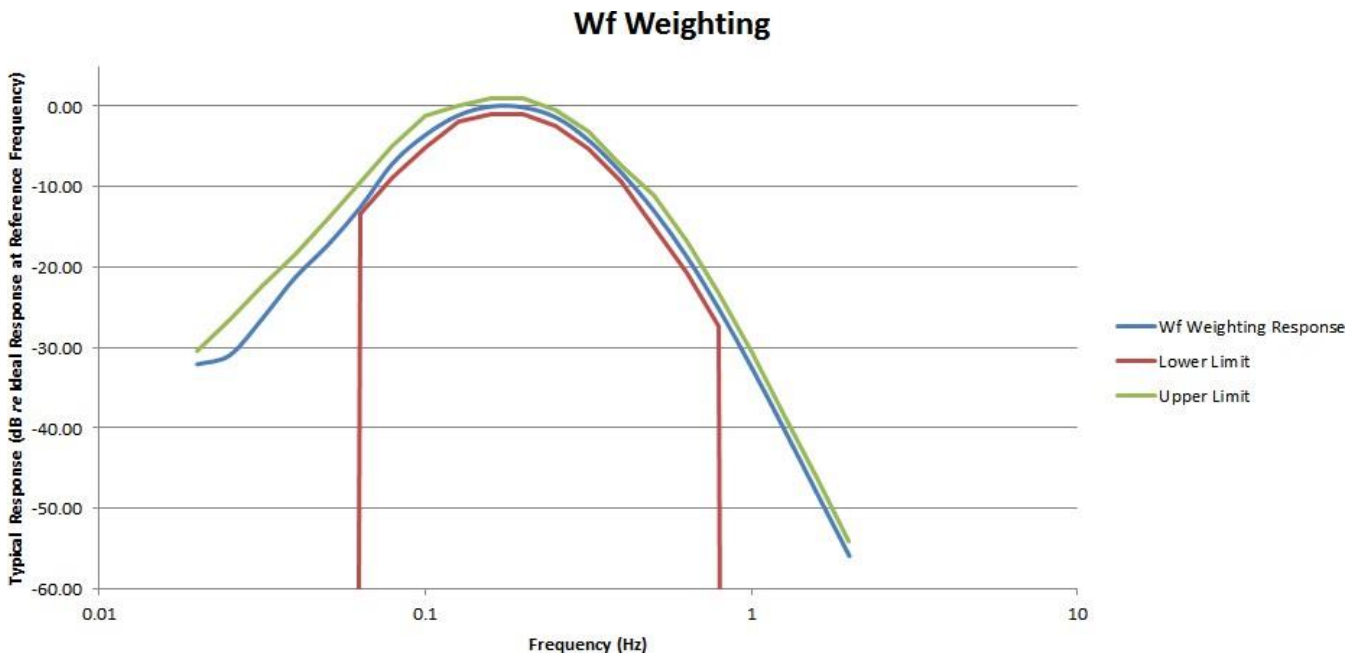
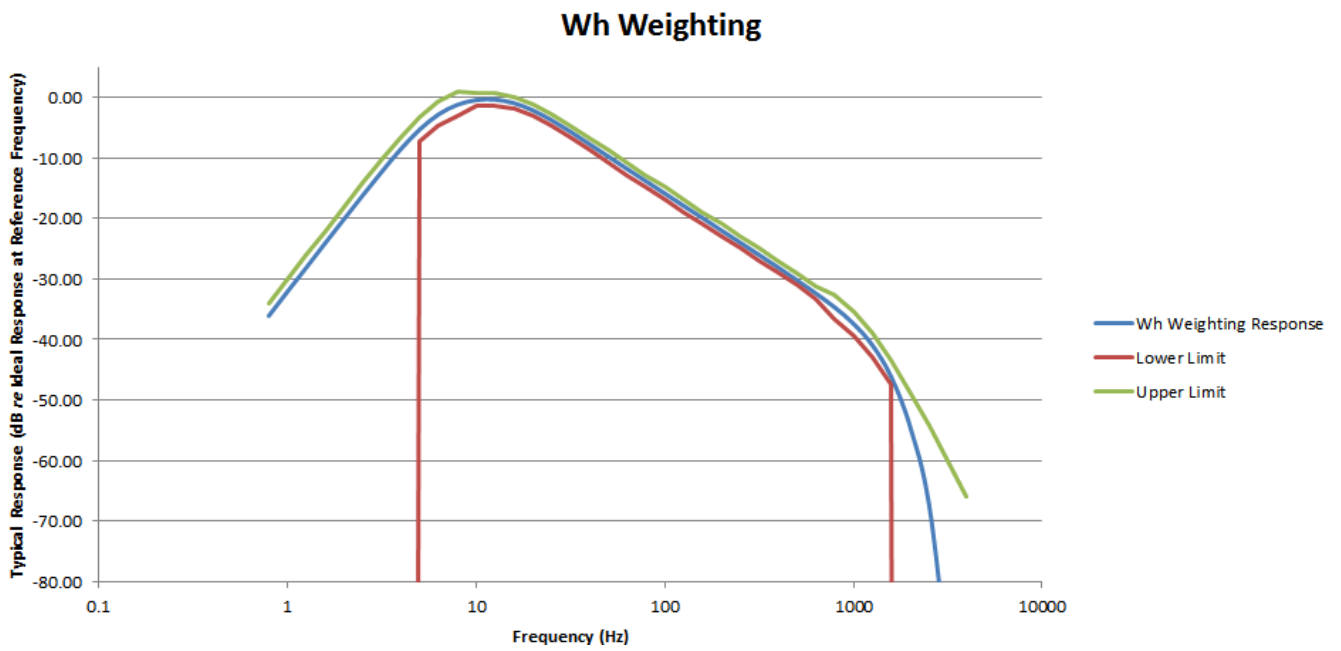
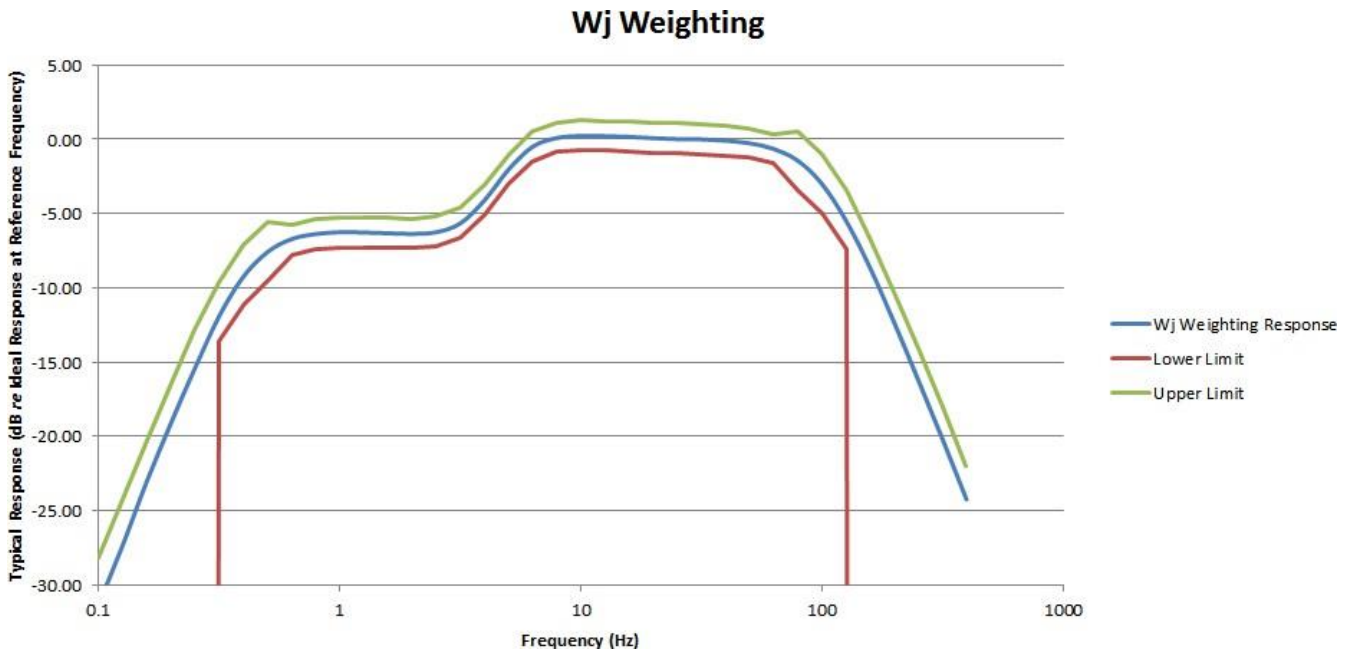


FIGURE A-13



**FIGURE A-14**



**FIGURE A-15**

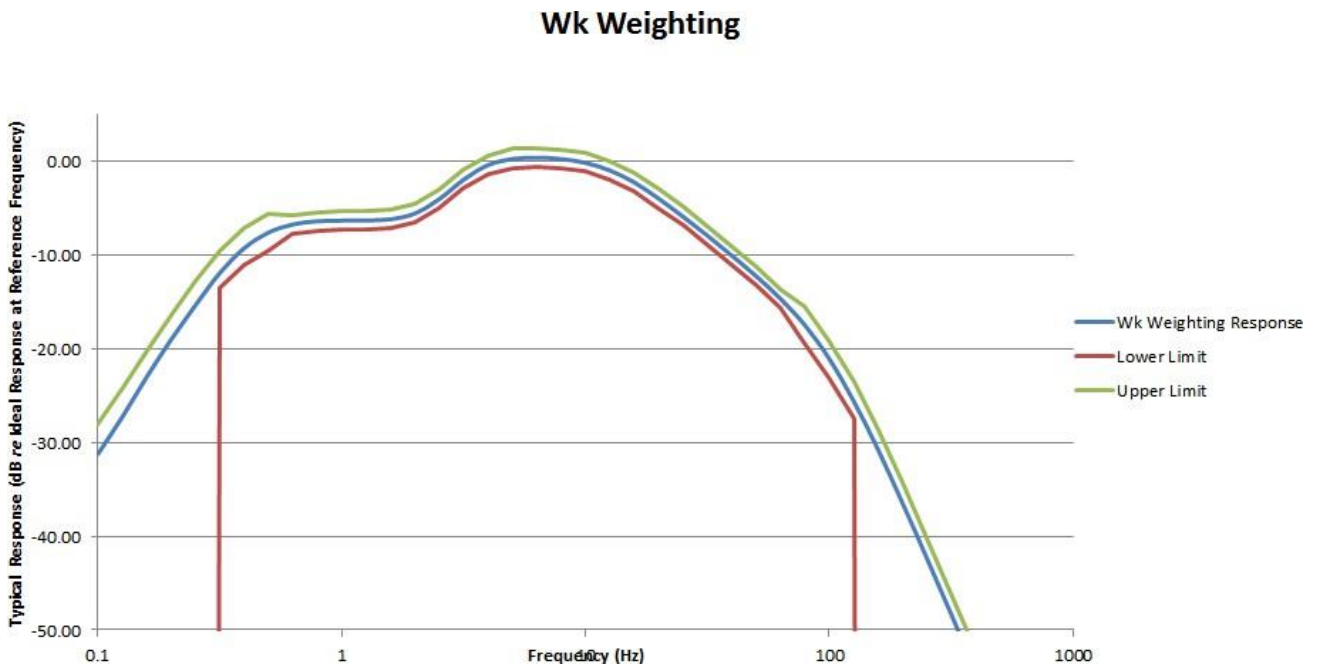
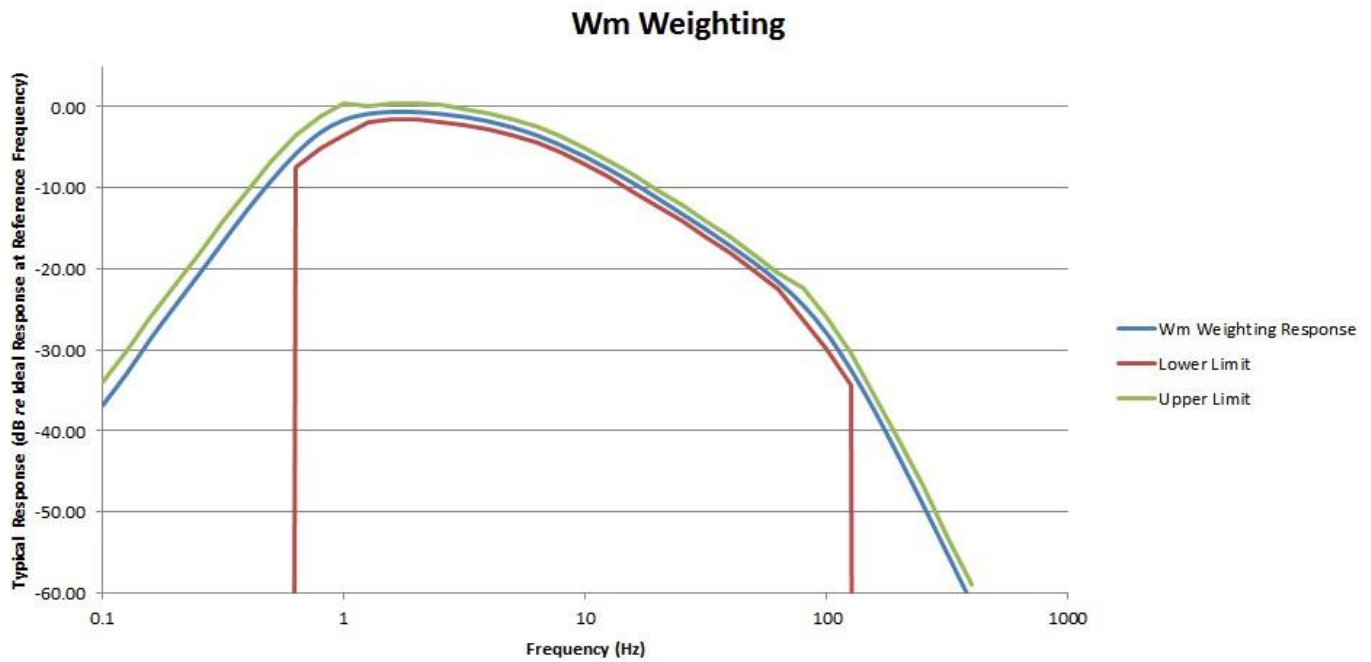


FIGURE A-16



## A.8 Frequency Weighting Tables

The following tables show frequency weighting values for the HVM200.

**TABLE A.7 Fa (Flat 0.4 Hz to 100 Hz)**

Freq (Hz)	Fa Ideal (dB)	Fa Typical (dB)	Tolerance (dB)
0.1000	-24.10	-25.19	+2/-∞
0.1259	-20.12	-21.21	+2/-∞
0.1585	-16.19	-16.92	+2/-∞
0.1995	-12.34	-12.95	+2/-∞
0.2512	-8.71	-9.26	+2/-∞
0.3162	-5.51	-5.84	+2/-2
0.3981	-3.05	-3.15	+2/-2
0.5012	-1.48	-1.46	+2/-2
0.6310	-0.65	-0.57	+1/-1
0.7943	-0.27	-0.17	+1/-1
1.000	-0.11	0.06	+1/-1
1.259	-0.04	0.00	+1/-1
1.585	-0.02	-0.02	+1/-1
1.995	-0.01	-0.03	+1/-1
2.512	0.00	-0.03	+1/-1
3.162	0.00	-0.03	+1/-1

Freq (Hz)	Fa Ideal (dB)	Fa Typical (dB)	Tolerance (dB)
3.981	0.00	-0.02	+1/-1
5.012	0.00	-0.03	+1/-1
6.310	0.00	-0.04	+1/-1
7.943	0.00	0.00	0
10.00	0.00	-0.01	+1/-1
12.59	0.00	0.00	+1/-1
15.85	0.00	0.02	+1/-1
19.95	-0.01	-0.02	+1/-1
25.12	-0.02	-0.05	+1/-1
31.62	-0.04	-0.03	+1/-1
39.81	-0.11	-0.12	+1/-1
50.12	-0.27	-0.27	+1/-1
63.10	-0.64	-0.65	+1/-1
79.43	-1.46	-1.44	+2/-2
100.0	-3.01	-2.99	+2/-2
125.9	-5.46	-5.47	+2/-2
158.5	-8.64	-8.65	+2/ -∞
199.5	-12.27	-12.32	+2/ -∞
251.2	-16.11	-16.20	+2/ -∞
316.2	-20.04	-20.16	+2/ -∞
398.1	-24.02	-24.22	+2/ -∞

**TABLE A.8 Fb (Flat 0.4 Hz to 1260 Hz) Frequency Weighting**

Freq (Hz)	Fb Ideal (dB)	Fb Typical (dB)	Tolerance (dB)
0.1000	-24.10	-25.24	+2 / -∞
0.1259	-20.12	-21.23	+2 / -∞
0.1585	-16.19	-16.94	+2 / -∞
0.1995	-12.34	-12.99	+2 / -∞
0.2512	-8.71	-9.29	+2 / -∞
0.3162	-5.51	-5.84	+2 / -2
0.3981	-3.05	-3.18	+2 / -2
0.5012	-1.48	-1.49	+2 / -2
0.6310	-0.65	-0.59	+1 / -1
0.7943	-0.27	-0.21	+1 / -1
1.000	-0.11	-0.08	+1 / -1
1.259	-0.04	-0.05	+1 / -1



Freq (Hz)	Fb Ideal (dB)	Fb Typical (dB)	Tolerance (dB)
1.585	-0.02	-0.04	+1 / -1
1.995	-0.01	-0.04	+1 / -1
2.512	0.00	-0.04	+1 / -1
3.162	0.00	-0.07	+1 / -1
3.981	0.00	-0.05	+1 / -1
5.012	0.00	-0.05	+1 / -1
6.310	0.00	-0.07	+1 / -1
7.943	0.00	-0.06	+1 / -1
10.00	0.00	-0.03	+1 / -1
12.59	0.00	-0.03	+1 / -1
15.85	0.00	-0.01	+1 / -1
19.95	0.00	-0.03	+1 / -1
25.12	0.00	-0.05	+1 / -1
31.62	0.00	-0.02	+1 / -1
39.81	0.00	-0.02	+1 / -1
50.12	0.00	-0.03	+1 / -1
63.10	0.00	-0.03	+1 / -1
79.43	0.00	0.00	0
100.0	0.00	-0.01	+1 / -1
125.9	0.00	-0.04	+1 / -1
158.5	0.00	-0.02	+1 / -1
199.5	0.00	-0.05	+1 / -1
251.2	-0.01	-0.06	+1 / -1
316.2	-0.02	-0.05	+1 / -1
398.1	-0.04	-0.10	+1 / -1
501.2	-0.11	-0.15	+1 / -1
631.0	-0.27	-0.31	+1 / -1
794.3	-0.64	-0.63	+2 / -2
1000	-1.46	-1.47	+2 / -2
1259	-3.01	-3.35	+2 / -2
1585	-5.46	-6.86	+2 / -∞
1995	-8.64	-12.55	+2 / -∞
2512	-12.27	-21.30	+2 / -∞
3162	-16.11	-39.09	+2 / -∞
3981	-20.04	-85.43	+2 / -∞

**TABLE A.9 Fc (Flat 6.3 Hz to 1260 Hz), Wh, and Wf Frequency Weighting.**

Freq (Hz)	Fc Ideal (dB)	Fc Typ (dB)	Wh Ideal (dB)	Wh Typ (dB)	Tolerance (dB)	Wf Ideal (dB)	Wf Typ (dB)	Tolerance (dB)
0.7943	-36	-36.06	-36	-36.10	+2 / -∞	-32.37	-32.08	+2 / -∞
1.000	-32	-32.08	-31.99	-32.08	+2 / -∞	-28.40	-30.95	+2 / -∞
1.259	-28.01	-28.08	-27.99	-28.09	+2 / -∞	-24.41	-26.39	+2 / -∞
1.585	-24.02	-24.08	-23.99	-24.07	+2 / -∞	-20.34	-21.30	+2 / -∞
1.995	-20.04	-20.09	-20.01	-20.08	+2 / -∞	-16.06	-17.28	+2 / -∞
2.512	-16.11	-16.16	-16.05	-16.12	+2 / -∞	-11.45	-12.58	+2 / -2
3.162	-12.27	-12.31	-12.18	-12.26	+2 / -∞	-6.86	-7.07	+2 / -2
3.981	-8.64	-8.70	-8.51	-8.56	+2 / -2	-3.16	-3.56	+2 / -2
5.012	-5.46	-5.50	-5.27	-5.32	+2 / -2	-0.92	-1.13	+4 / -1
6.310	-3.01	-3.02	-2.77	-2.83	+2 / -2	0.04	-0.02	+1 / -1
7.943	-1.46	-1.52	-1.18	-1.25	+2 / -2	-0.06	-0.12	+1 / -1
10.00	-0.64	-0.67	-0.43	-0.46	+1 / -1	-1.41	-1.39	+1 / -1
12.59	-0.27	-0.31	-0.38	-0.39	+1 / -1	-4.22	-4.21	+1 / -1
15.85	-0.11	-0.12	-0.96	-0.99	+1 / -1	-8.22	-8.22	+1 / -1
19.95	-0.04	-0.08	-2.14	-2.17	+1 / -1	-13.05	-12.96	+2 / -2
25.12	-0.02	-0.06	-3.78	-3.83	+1 / -1	-18.73	-18.63	+2 / -2
31.62	-0.01	-0.02	-5.69	-5.71	+1 / -1	-25.30	-25.22	+2 / -2
39.81	0	-0.03	-7.72	-7.75	+1 / -1	-32.57	-32.49	+2 / -∞
50.12	0	-0.03	-9.78	-9.80	+1 / -1	-40.26	-40.20	+2 / -∞
63.10	0	-0.03	-11.83	-11.86	+1 / -1	-48.14	-48.11	+2 / -∞
79.43	0	0.00	-13.88	-13.88	0	-56.11	-55.96	+2 / -∞
100.0	0	-0.01	-15.91	-15.92	+1 / -1			
125.9	0	-0.04	-17.93	-17.97	+1 / -1			
158.5	0	-0.02	-19.94	-19.97	+1 / -1			
199.5	0	-0.05	-21.95	-22.01	+1 / -1			
251.2	-0.01	-0.06	-23.96	-24.04	+1 / -1			
316.2	-0.02	-0.05	-25.98	-26.06	+1 / -1			
398.1	-0.04	-0.10	-28	-28.13	+1 / -1			
501.2	-0.11	-0.15	-30.07	-30.21	+1 / -1			
631.0	-0.27	-0.31	-32.23	-32.40	+1 / -1			
794.3	-0.64	-0.63	-34.6	-34.70	+1 / -1			
1000	-1.46	-1.47	-37.42	-37.41	+2 / -2			
1259	-3.01	-3.35	-40.97	-40.97	+2 / -2			

Freq (Hz)	Fc Ideal (dB)	Fc Typ (dB)	Wh Ideal (dB)	Wh Typ (dB)	Tolerance (dB)	Wf Ideal (dB)	Wf Typ (dB)	Tolerance (dB)
1585	-5.46	-6.86	-45.42	-46.21	+2 / -2			
1995	-8.64	-12.55	-50.6	-54.40	+2 / -∞			
2512	-12.27	-21.30	-56.23	-67.23	+2 / -∞			
3162	-16.11	-39.09	-62.07	-92.87	+2 / -∞			
3981	-20.04	-86.14	-68.01	-101.37	+2 / -∞			

**TABLE A.10 Wm, Wc, and Wd Frequency Weightings**

Freq (Hz)	Wm Ideal (dB)	WmTyp (dB)	Wc Ideal (dB)	Wc Typ (dB)	Wd Ideal (dB)	Wd Typ (dB)	Tolerance (dB)
0.100	-36	-36.81	-24.10	-25.20	-24.09	-25.23	+2 / -∞
0.1259	-32	-32.86	-20.12	-21.23	-20.12	-21.21	+2 / -∞
0.1585	-28.01	-28.53	-16.19	-16.93	-16.18	-16.96	+2 / -∞
0.1995	-24.02	-24.53	-12.34	-13.00	-12.32	-13.00	+2 / -∞
0.2512	-20.05	-20.60	-8.71	-9.30	-8.68	-9.28	+2 / -∞
0.3162	-16.12	-16.58	-5.51	-5.88	-5.47	-5.78	+2 / -2
0.3981	-12.29	-12.67	-3.05	-3.17	-2.98	-3.10	+2 / -2
0.5012	-8.67	-9.04	-1.47	-1.50	-1.37	-1.40	+2 / -2
0.6310	-5.51	-5.76	-0.64	-0.60	-0.5	-0.45	+1 / -1
0.7943	-3.09	-3.18	-0.25	-0.23	-0.08	-0.06	+1 / -1
1.00	-1.59	-1.59	-0.08	-0.06	0.1	0.12	+1 / -1
1.259	-0.85	-0.85	+0.00	-0.01	0.06	0.06	+1 / -1
1.585	-0.59	-0.61	+0.06	0.02	-0.26	-0.28	+1 / -1
1.995	-0.61	-0.64	+0.10	0.05	-1	-1.06	+1 / -1
2.512	-0.82	-0.86	+0.15	0.09	-2.23	-2.30	+1 / -1
3.162	-1.19	-1.24	+0.19	0.12	-3.88	-3.93	+1 / -1
3.981	-1.74	-1.78	+0.21	0.14	-5.78	-5.84	+1 / -1
5.012	-2.5	-2.55	+0.11	0.04	-7.78	-7.85	+1 / -1
6.310	-3.49	-3.52	-0.23	-0.31	-9.83	-9.92	+1 / -1
7.943	-4.7	-4.76	-0.97	-1.06	-11.87	-11.91	0
10.0	-6.12	-6.16	-2.20	-2.25	-13.91	-13.95	+1 / -1
12.59	-7.71	-7.75	-3.84	-3.88	-15.93	-15.98	+1 / -1
15.85	-9.44	-9.44	-5.74	-5.74	-17.95	-17.95	+1 / -1

Freq (Hz)	Wm Ideal (dB)	WmTyp (dB)	Wc Ideal (dB)	Wc Typ (dB)	Wd Ideal (dB)	Wd Typ (dB)	Tolerance (dB)
19.95	-11.25	-11.30	-7.75	-7.81	-19.97	-20.02	+1 / -1
25.12	-13.14	-13.19	-9.80	-9.85	-21.98	-22.04	+1 / -1
31.62	-15.09	-15.12	-11.87	-11.91	-24.01	-24.05	+1 / -1
39.81	-17.1	-17.14	-13.97	-14.00	-26.08	-26.12	+1 / -1
50.12	-19.23	-19.26	-16.15	-16.20	-28.24	-28.28	+1 / -1
63.10	-21.58	-21.62	-18.55	-18.59	-30.62	-30.67	+1 / -1
79.43	-24.38	-24.40	-21.37	-21.39	-33.43	-33.45	+2 / -2
100.0	-27.93	-27.95	-24.94	-24.96	-36.99	-37.02	+2 / -2
125.9	-32.37	-32.43	-29.39	-29.45	-41.43	-41.50	+2 / -2
158.5	-37.55	-37.60	-34.57	-34.63	-46.62	-46.68	+2 / -∞
199.5	-43.18	-43.28	-40.20	-40.32	-52.24	-52.36	+2 / -∞
251.2	-49.02	-49.17	-46.04	-46.21	-58.09	-58.25	+2 / -∞
316.2	-54.95	-55.16	-51.98	-52.19	-64.02	-64.23	+2 / -∞
398.1	-60.92	-61.23	-57.95	-58.29	-70	-70.30	+2 / -∞

**TABLE A.11 We, Wj, and Wk Frequency Weighting**

Freq (Hz)	We Ideal (dB)	We Typ (dB)	Wj Ideal (dB)	Wj Typ (dB)	Wk Ideal (dB)	Wk Typ (dB)	Tolerance dB
0.100	-24.08	-25.22	-30.18	-31.27	-30.11	-31.20	+2 / -∞
0.1259	-20.09	-21.22	-26.20	-27.28	-26.14	-27.24	+2 / -∞
0.1585	-16.14	-16.91	-22.27	-22.99	-22.21	-22.98	+2 / -∞
0.1995	-12.27	-12.92	-18.42	-19.08	-18.37	-19.00	+2 / -∞
0.2512	-8.60	-9.20	-14.79	-15.37	-14.74	-15.32	+2 / -∞
0.3162	-5.36	-5.66	-11.60	-11.89	-11.55	-11.88	+2 / -2
0.3981	-2.86	-2.99	-9.15	-9.25	-9.11	-9.24	+2 / -2
0.5012	-1.27	-1.28	-7.58	-7.59	-7.56	-7.57	+2 / -2
0.6310	-0.55	-0.48	-6.77	-6.72	-6.77	-6.71	+1 / -1
0.7943	-0.52	-0.47	-6.42	-6.38	-6.44	-6.37	+1 / -1
1.00	-1.11	-1.08	-6.30	-6.26	-6.33	-6.30	+1 / -1
1.259	-2.29	-2.29	-6.28	-6.28	-6.29	-6.28	+1 / -1
1.585	-3.91	-3.92	-6.32	-6.33	-6.13	-6.16	+1 / -1
1.995	-5.80	-5.82	-6.34	-6.37	-5.50	-5.54	+1 / -1
2.512	-7.81	-7.85	-6.22	-6.26	-3.97	-4.01	+1 / -1
3.162	-9.85	-9.87	-5.60	-5.66	-1.86	-1.93	+1 / -1
3.981	-11.89	-11.95	-4.08	-4.11	-0.31	-0.38	+1 / -1

Freq (Hz)	We Ideal (dB)	We Typ (dB)	Wj Ideal (dB)	Wj Typ (dB)	Wk Ideal (dB)	Wk Typ (dB)	Tolerance dB
5.012	-13.93	-13.98	-1.99	-2.04	+0.33	0.28	+1 / -1
6.310	-15.95	-16.00	-0.47	-0.51	+0.46	0.42	+1 / -1
7.943	-17.97	-18.04	+0.14	0.08	+0.32	0.28	0
10.0	-19.98	-20.02	+0.26	0.23	-0.10	-0.14	+1 / -1
12.59	-21.99	-22.01	+0.22	0.21	-0.93	-0.95	+1 / -1
15.85	-23.99	-23.99	+0.16	0.16	-2.22	-2.22	+1 / -1
19.95	-26.00	-26.05	+0.10	0.07	-3.91	-3.95	+1 / -1
25.12	-28.01	-28.06	+0.06	0.01	-5.84	-5.88	+1 / -1
31.62	-30.04	-30.06	+0.00	-0.01	-7.89	-7.90	+1 / -1
39.81	-32.11	-32.14	-0.08	-0.10	-10.01	-10.04	+1 / -1
50.12	-34.26	-34.30	-0.25	-0.27	-12.21	-12.24	+1 / -1
63.10	-36.64	-36.68	-0.63	-0.65	-14.62	-14.66	+1 / -1
79.43	-39.46	-39.47	-1.45	-1.44	-17.47	-17.48	+2 / -2
100.0	-43.01	-43.03	-3.01	-3.01	-21.04	-21.05	+2 / -2
125.9	-47.46	-47.51	-5.45	-5.49	-25.50	-25.55	+2 / -2
158.5	-52.64	-52.69	-8.64	-8.66	-30.69	-30.73	+2 / -∞
199.5	-58.27	-58.37	-12.26	-12.34	-36.32	-36.42	+2 / -∞
251.2	-64.11	-64.21	-16.11	-16.22	-42.16	-42.32	+2 / -∞
316.2	-70.04	-70.24	-20.04	-20.18	-48.10	-48.30	+2 / -∞
398.1	-76.02	-76.29	-24.02	-24.25	-54.08	-54.40	+2 / -∞

## A.9 Integration Weighting Limits

All data presented is with a reference sensitivity of 1 mV/m/s<sup>2</sup>. The amplitude values on the tables and figures scale according to the ratio of selected sensor sensitivity values to 1 mV/m/s<sup>2</sup>.

**TABLE A.12**

Weighting	Single Integration		Double Integration	
	Noise Floor (m/s)	Max (m/s)	Noise Floor (m)	Max (m)
<b>Fa</b>	0.0121	1403.690	0.0150	801.367
<b>Fb</b>	0.0220	1403.690	0.0173	801.367
<b>Fc</b>	0.0003	84.283	0.0003	3.235
<b>Wb</b>	0.0068	563.341	0.0060	317.432
<b>Wc</b>	0.0163	1403.690	0.0143	801.367
<b>Wd</b>	0.0155	1415.048	0.0111	801.367

<b>We</b>	0.0108	1434.733	0.0102	804.139
<b>Wf</b>	0.0802	5740.123	0.1707	8823.712
<b>Wh</b>	0.0003	87.044	0.0002	3.235
<b>Wj</b>	0.0080	695.458	0.0077	397.953
<b>Wk</b>	0.0083	698.669	0.0067	400.711
<b>Wm</b>	0.0049	698.620	0.0034	204.094

For the following charts, the valid measurement range for each weighting is shown between the noise floor and the maximum.

**FIGURE A-17**

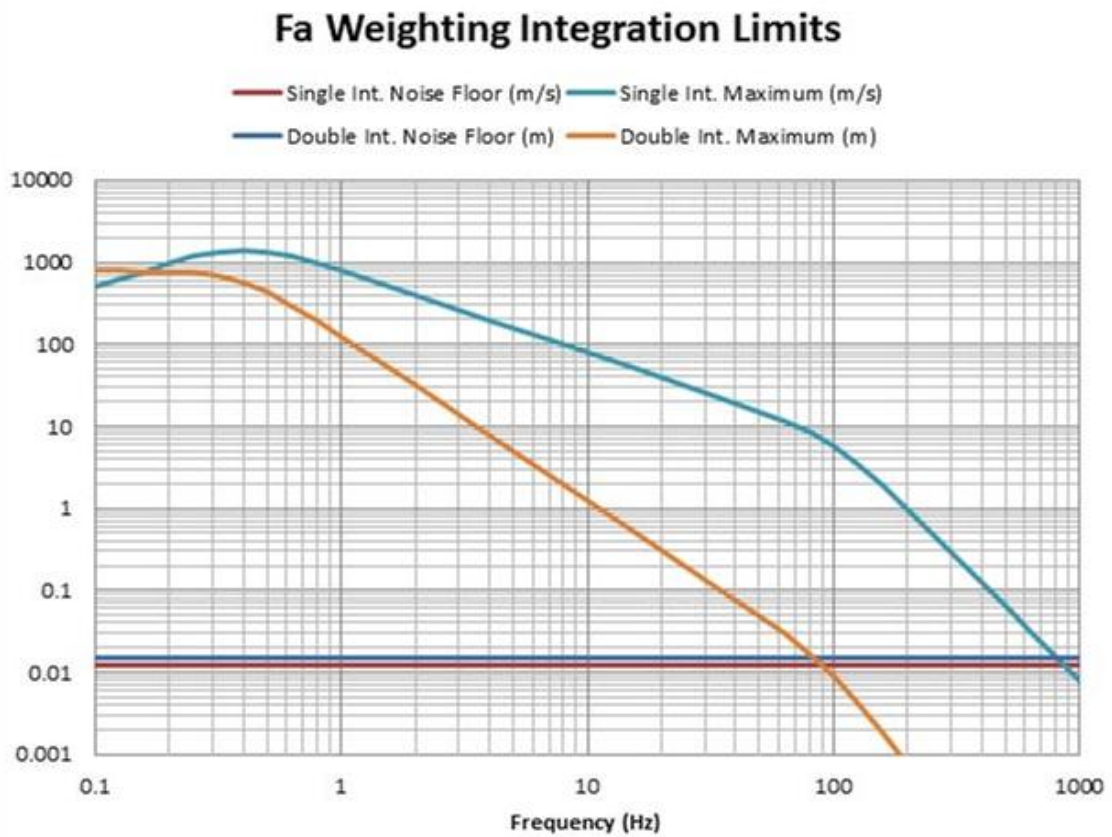


FIGURE A-18

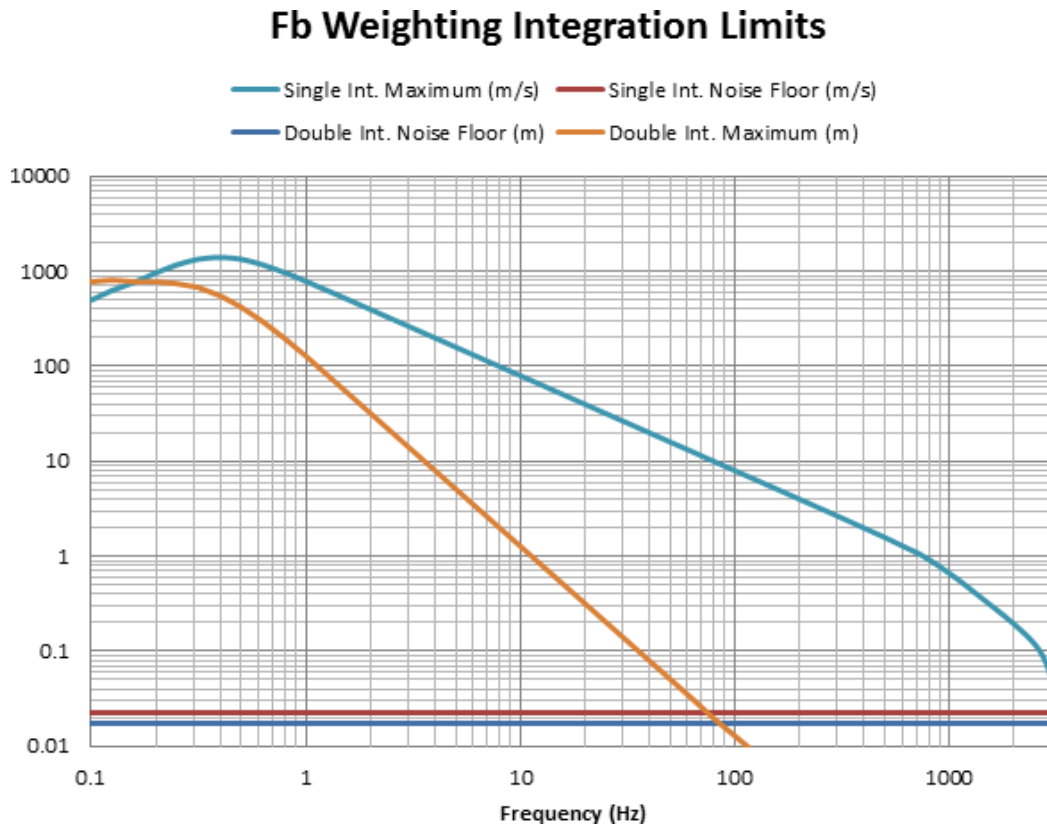
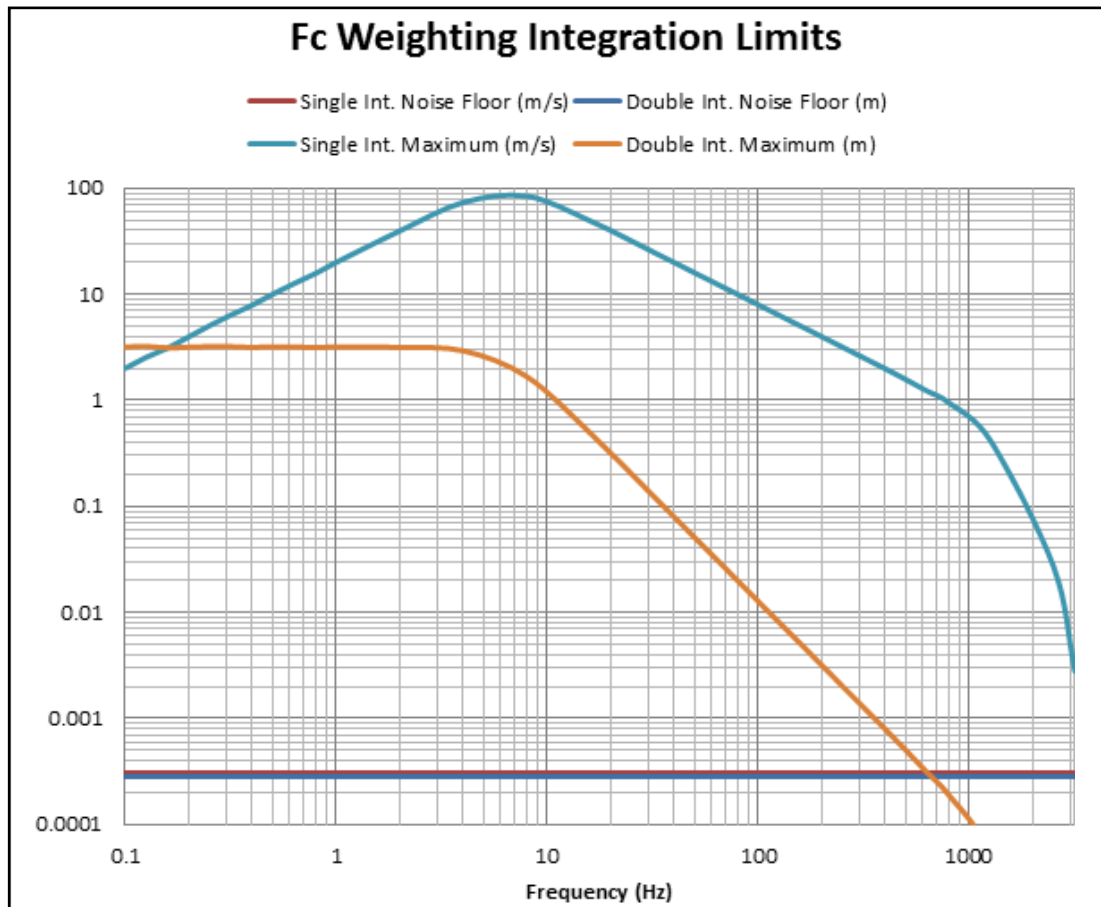
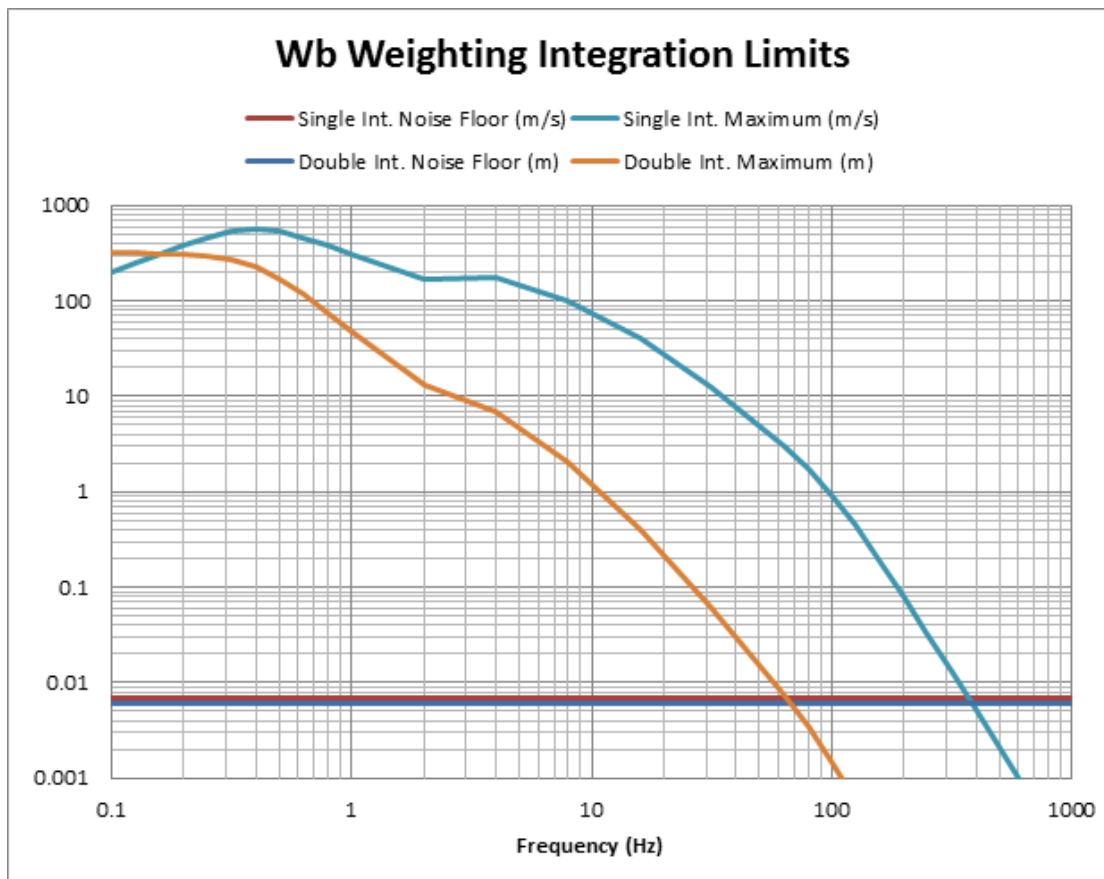


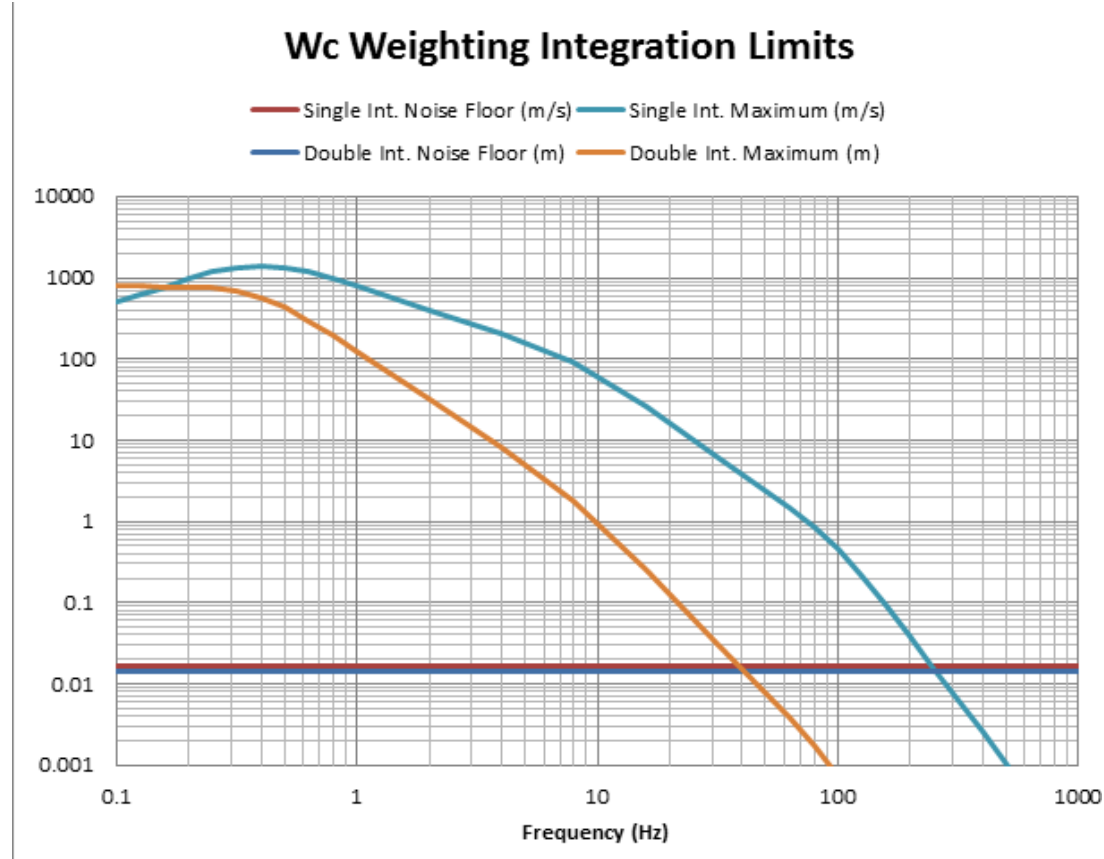
FIGURE A-19



**FIGURE A-20**

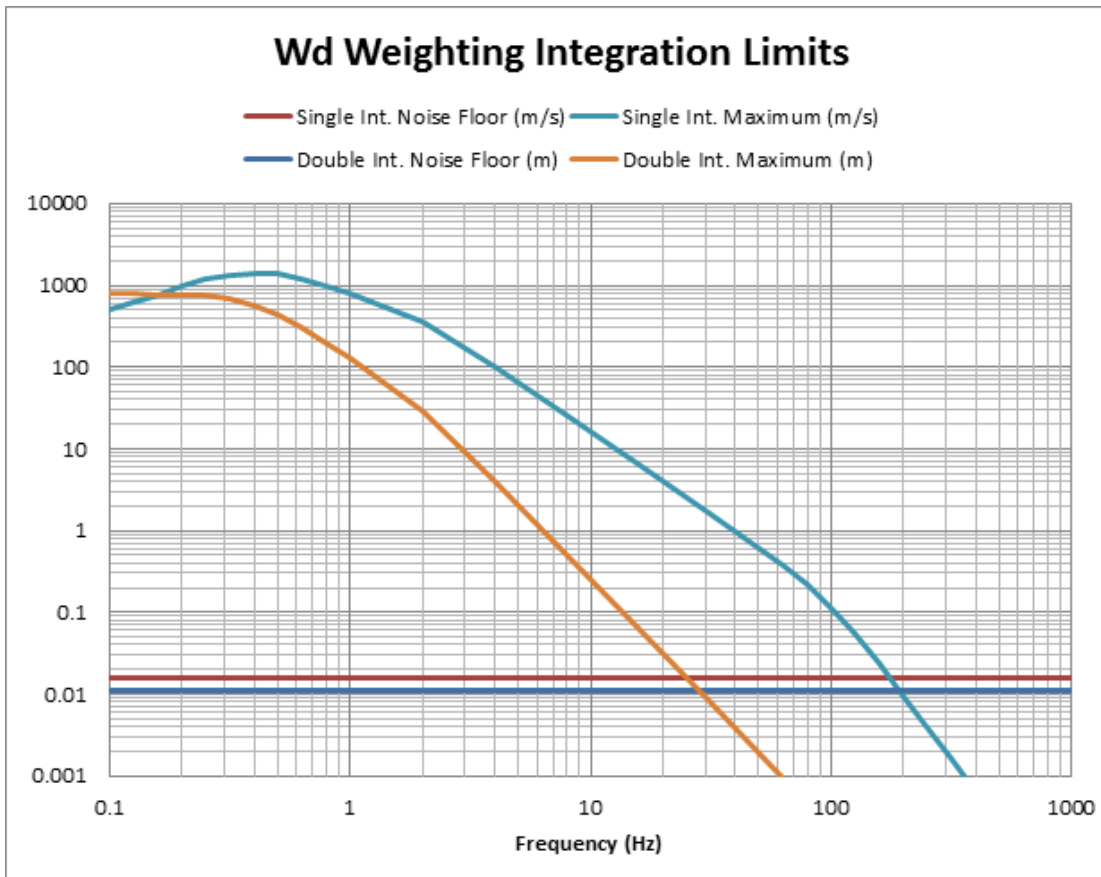


**FIGURE A-21**





**FIGURE A-22**



**FIGURE A-23**

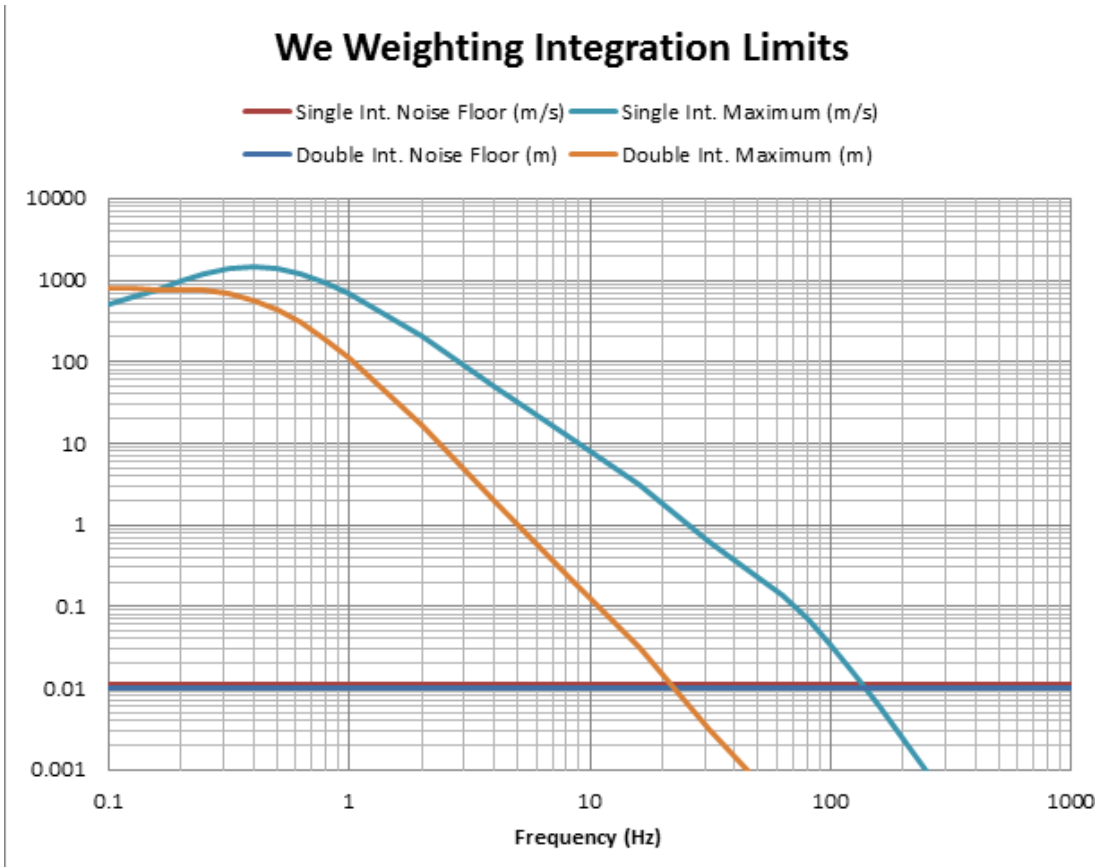


FIGURE A-24

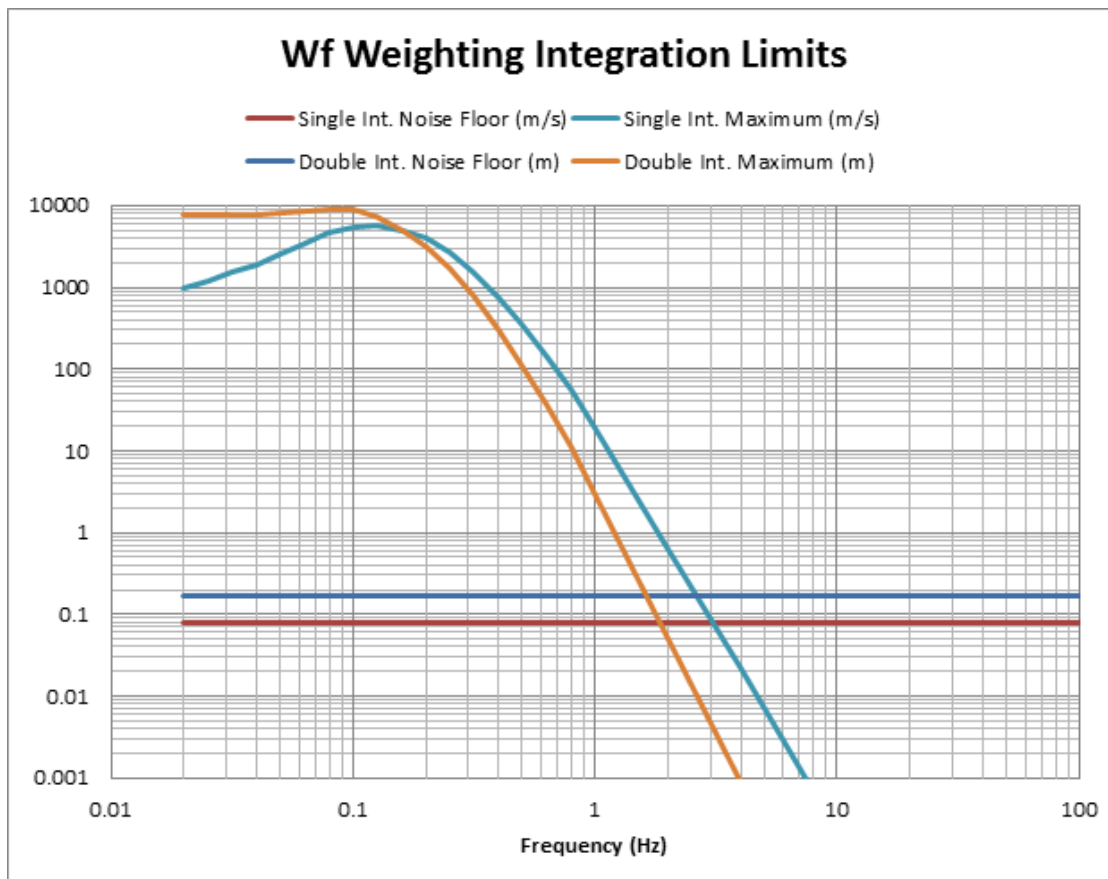
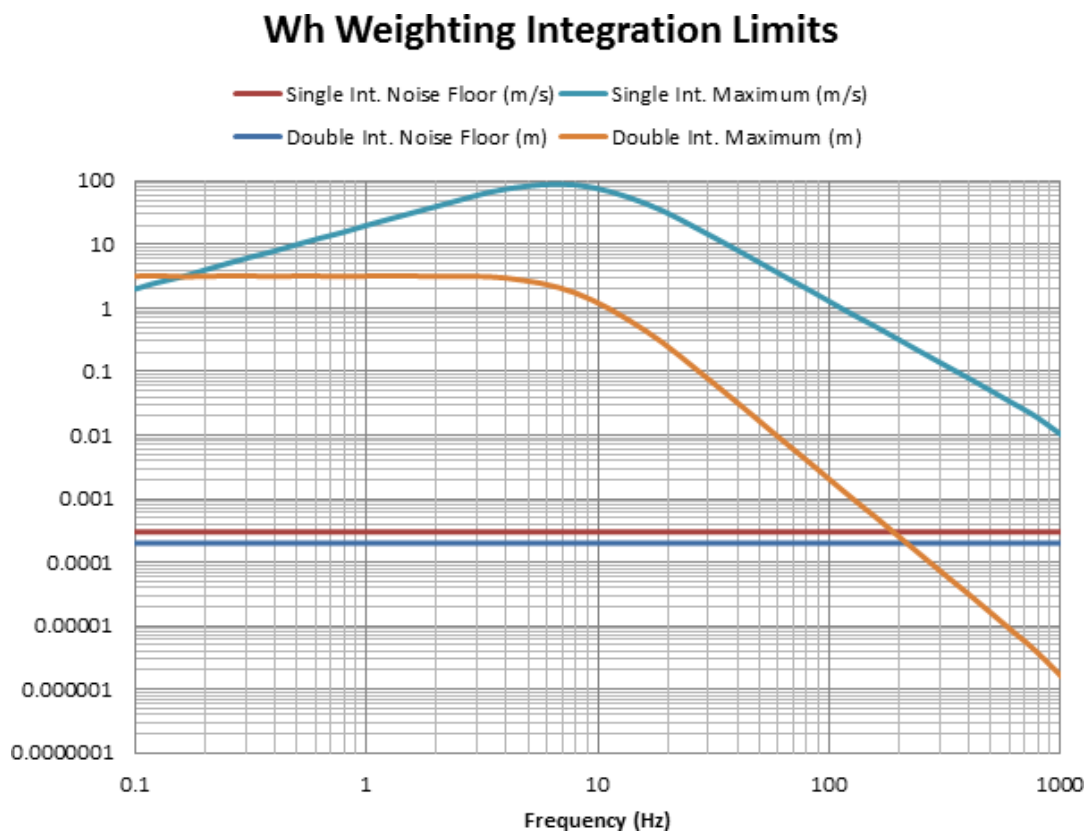
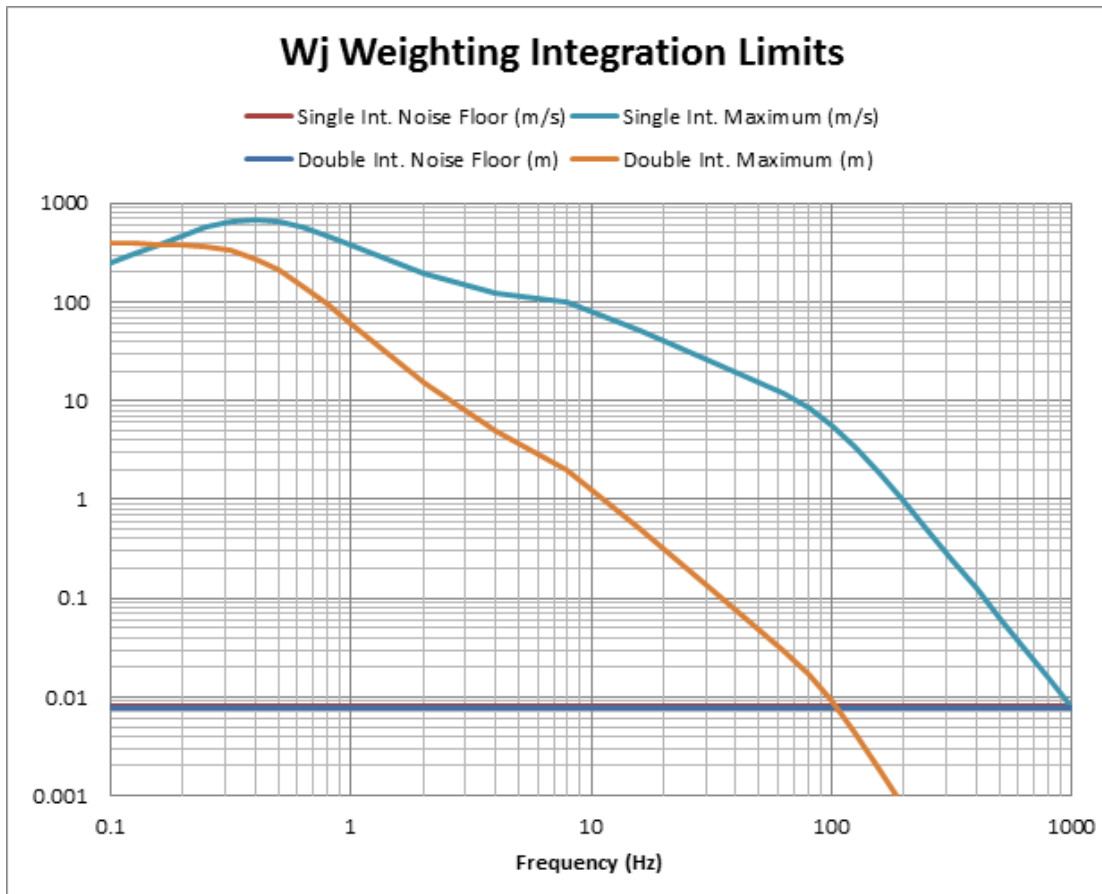


FIGURE A-25



**FIGURE A-26**



**FIGURE A-27**

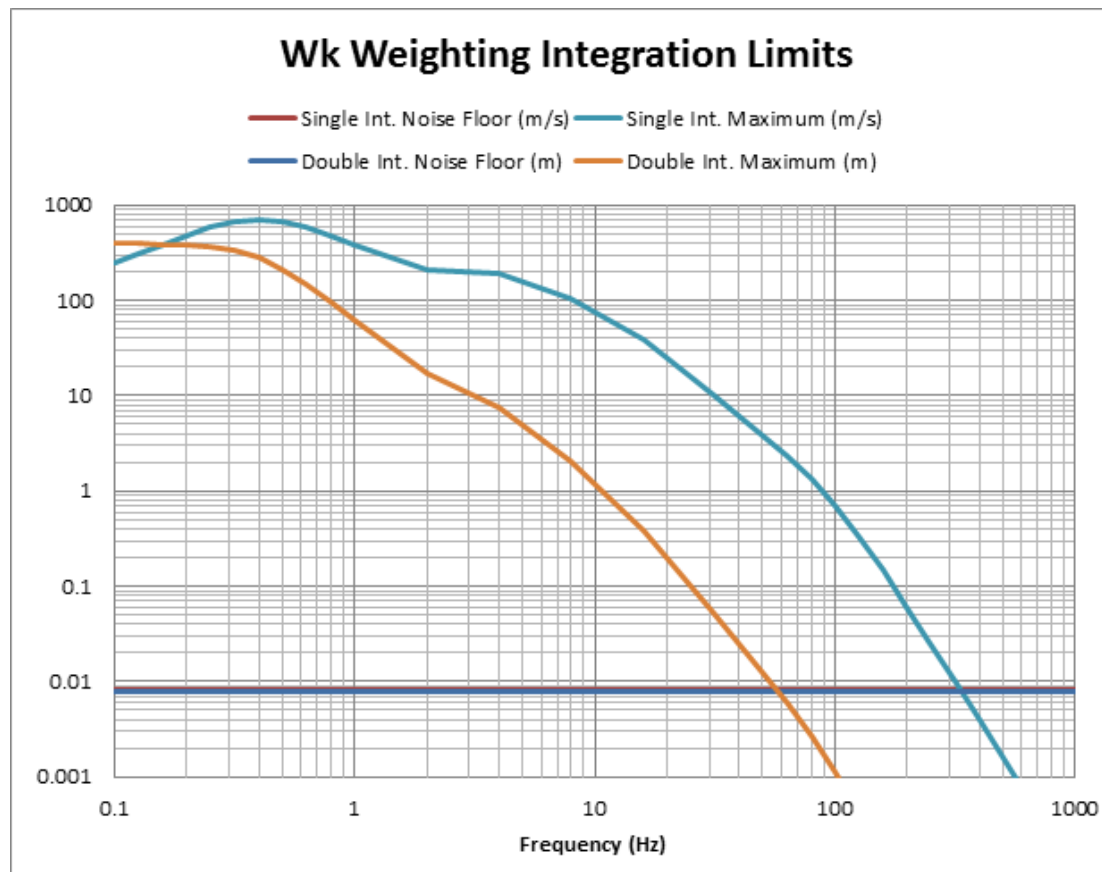
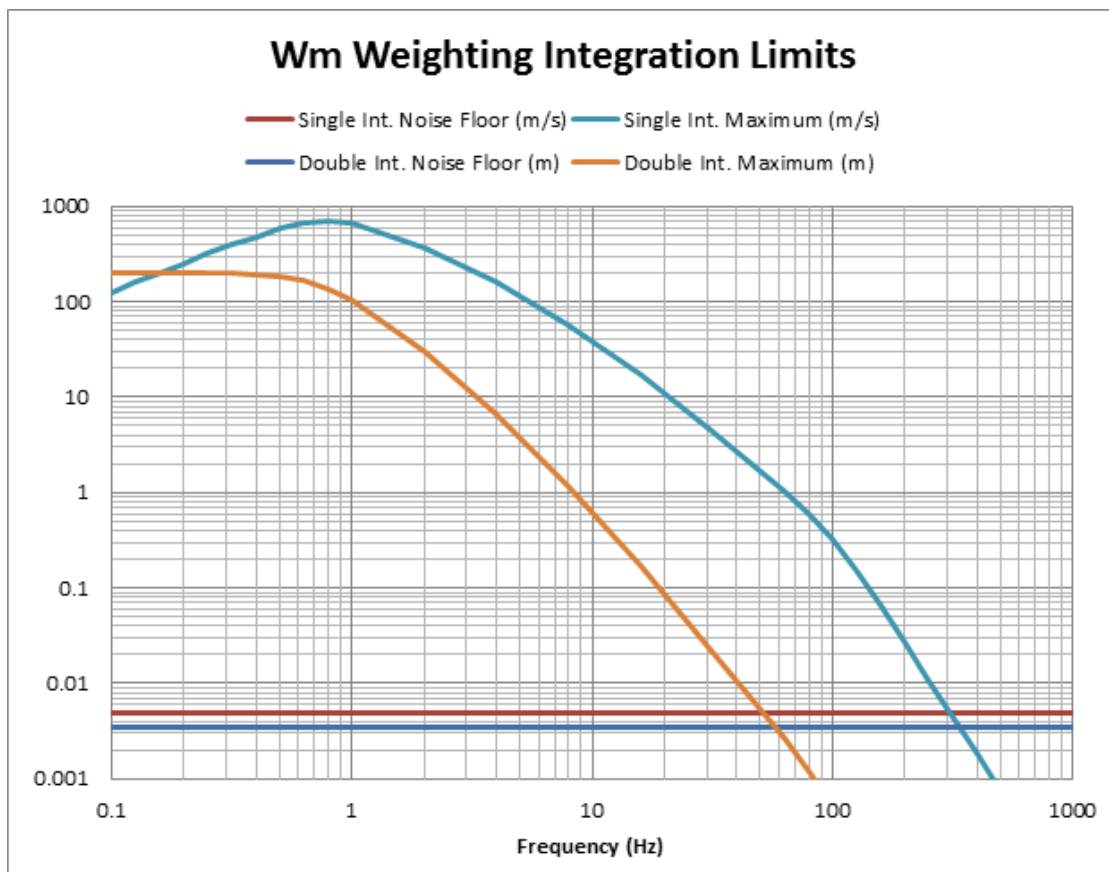


FIGURE A-28



## A.10 1/1 & 1/3 Octave Band Filters

Octave Band Analysis (OBA) is an optional feature for the HVM200.

### OBA Compliance

- IEC 61260-1:2014 Class 1
- ANSI S1.11-2014 Part 1, Class 1

### OBA General Specifications

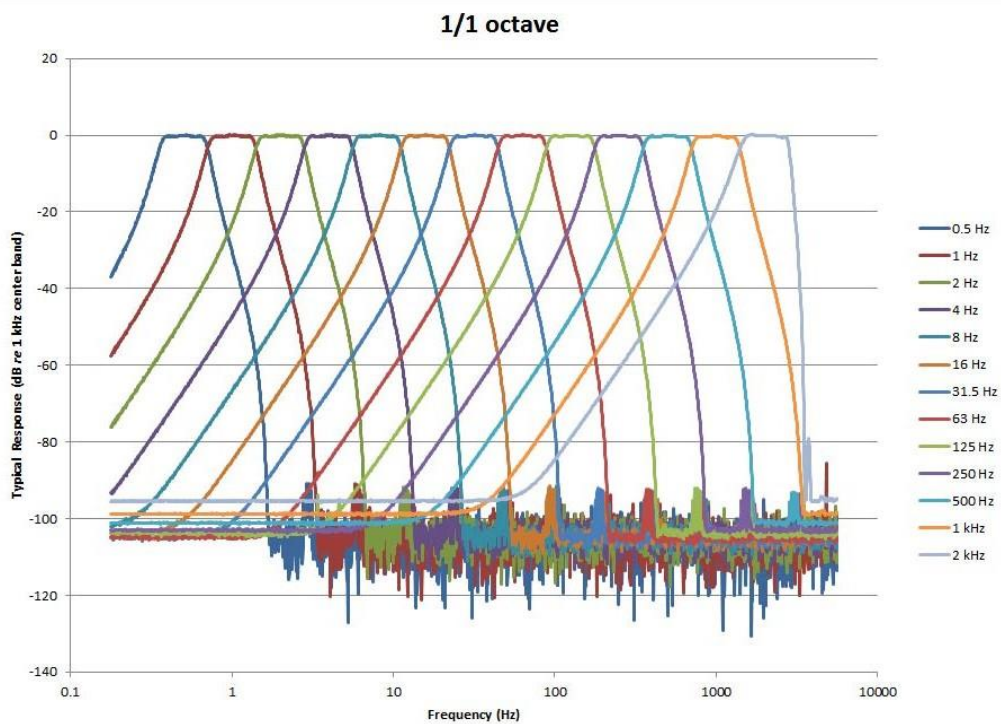
- 1/1 Octave Filters: 0.5 Hz to 2000 Hz
- 1/3 Octave Filters: 0.4 Hz to 2500 Hz
- Weighting: Unweighted
- Measured Values: RMS and Peak OBA Filter Responses

TABLE A.13 1/1 OBA Filter Responses

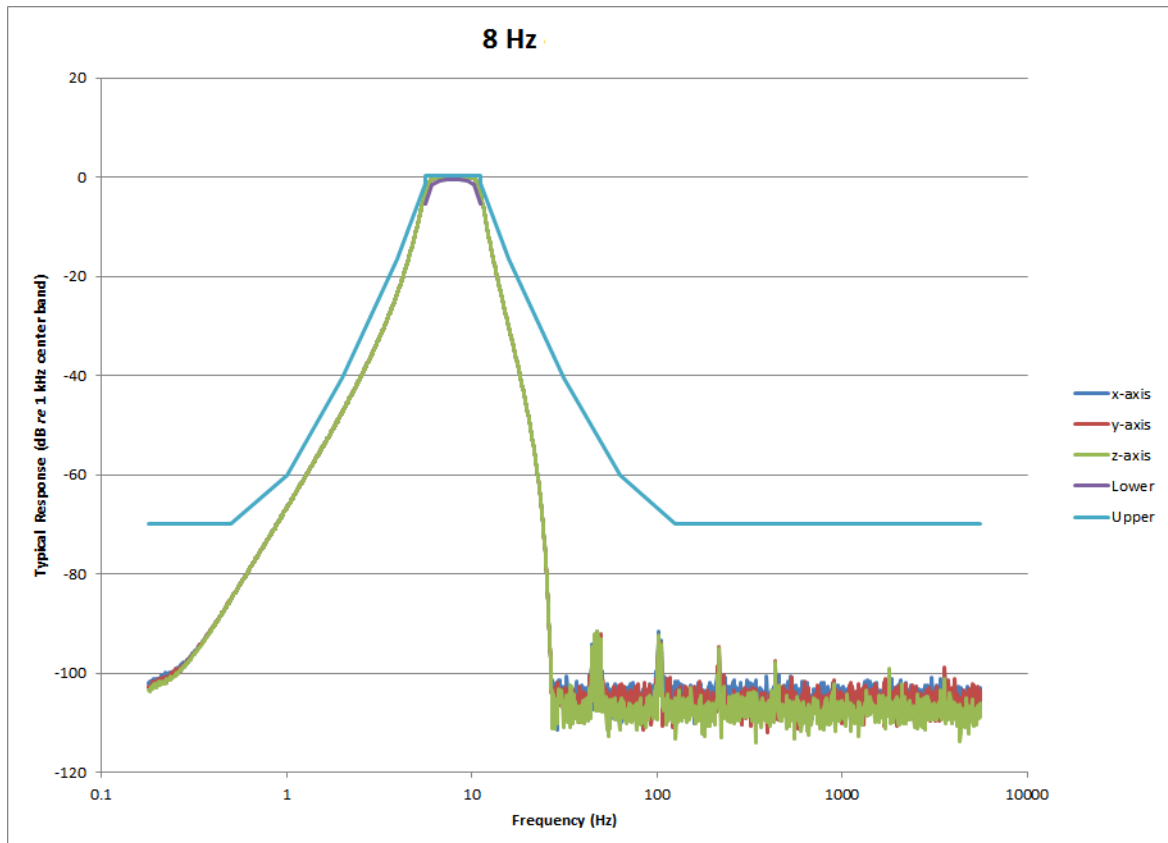
1/1 Octave Measurement Range			
Frequency (Hz)	Maximum Noise Floor (mV)	Lower Limit Linearity (mV)	Overload (V)
0.5	0.022	0.14	5.01
1	0.017	0.21	5.01
2	0.0144	0.17	5.01

4	0.0143	0.14	5.01
8	0.01415	0.13	5.01
16	0.01405	0.13	5.01
31.5	0.01408	0.09	5.01
63	0.0149	0.085	5.01
125	0.0171	0.08	5.01
250	0.0205	0.07	5.01
500	0.02417	0.08	5.01
1000	0.02973	0.08	5.01
2000	0.0385	0.14	5.01

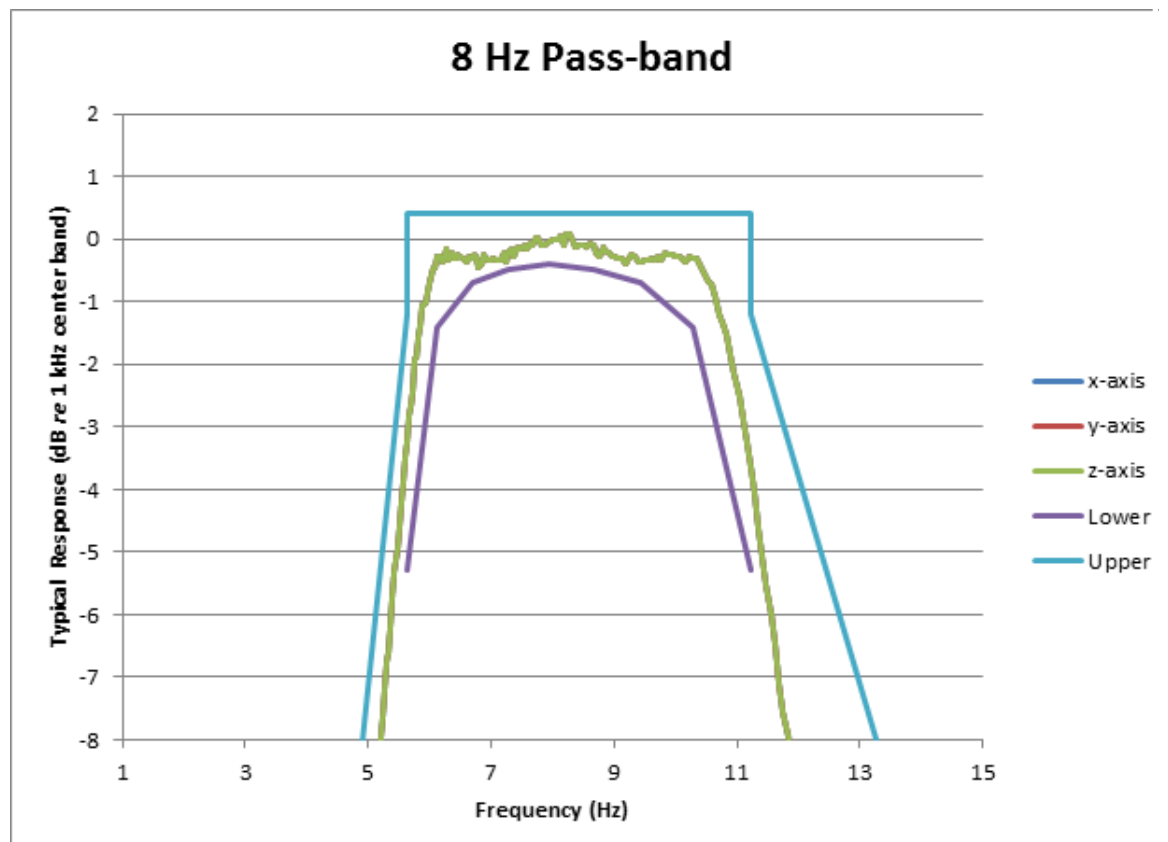
**FIGURE A-29 1/1 Octave Filter Response Summary Graph**



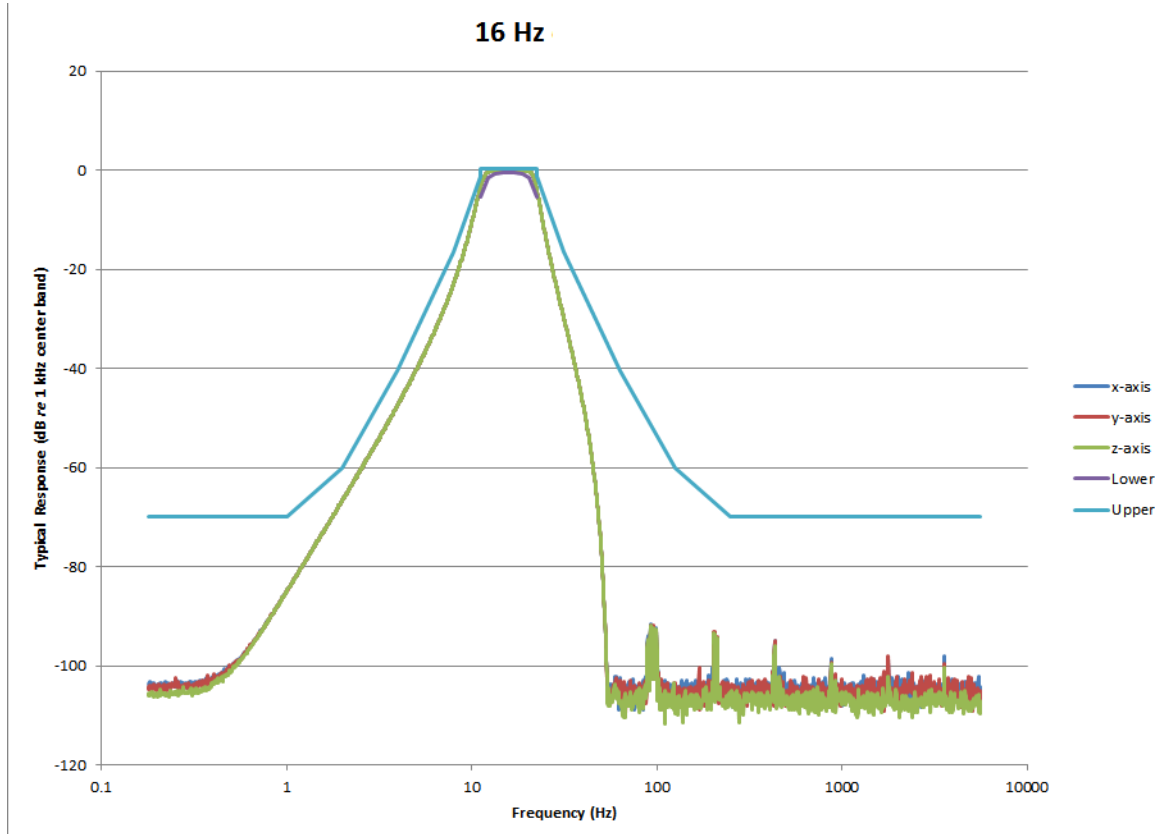
**FIGURE A-30 1/1 OBA 8.0 Hz Filter Response**



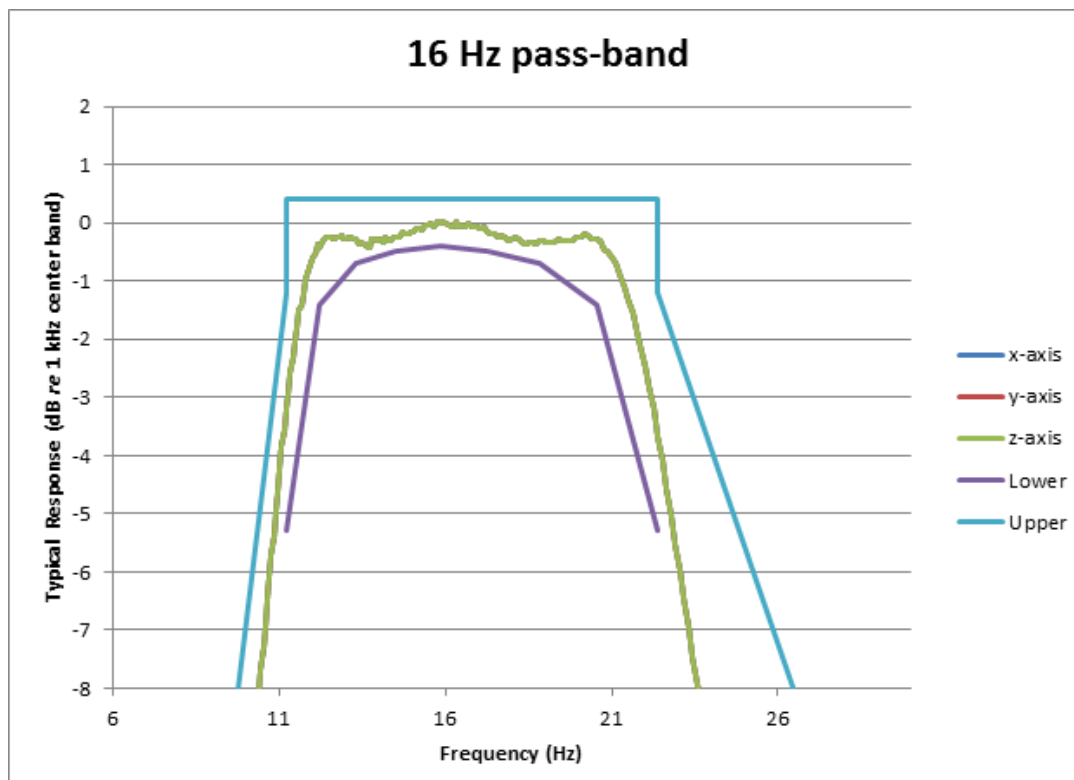
**FIGURE A-31 1/1 OBA 8.0 Hz Filter Response: Pass-band**



**FIGURE A-32 1/1 OBA 16.0 Hz Filter Response**



**FIGURE A-33 1/1 OBA 16.0 Hz Filter Response: Pass-band**

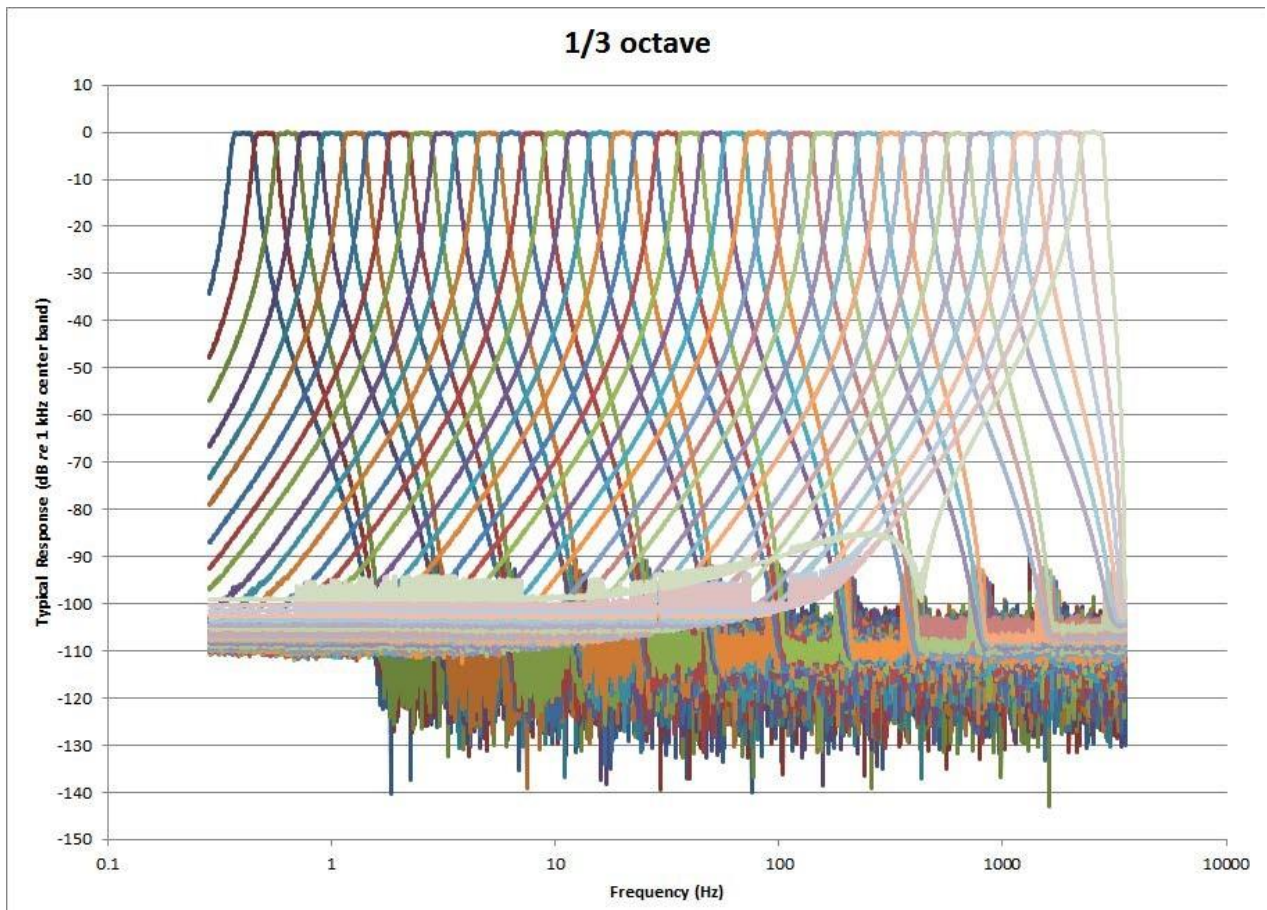


**TABLE A.14 1/3 OBA Filter Responses**

Frequency (Hz)	Maximum Noise Floor (mV)	Lower Limit Linearity (mV)	Overload (V)
0.4	0.022	0.13	5.01
0.5	0.02	0.13	5.01
0.63	0.018	0.14	5.01
0.8	0.017	0.15	5.01
1	0.0155	0.18	5.01
1.25	0.0148	0.21	5.01
1.6	0.0144	0.17	5.01
2	0.01435	0.14	5.01
2.5	0.01432	0.14	5.01
3.15	0.0143	0.14	5.01
4	0.01425	0.14	5.01
5	0.0142	0.13	5.01
6.3	0.01415	0.13	5.01
8	0.0141	0.13	5.01
10	0.01407	0.13	5.01
12.5	0.01405	0.13	5.01
16	0.01403	0.11	5.01
20	0.01401	0.1	5.01
25	0.014	0.09	5.01
31.5	0.01401	0.085	5.01
40	0.01408	0.085	5.01
50	0.01418	0.085	5.01
63	0.0143	0.08	5.01
80	0.0149	0.08	5.01
100	0.0155	0.08	5.01
125	0.0162	0.075	5.01
160	0.0171	0.07	5.01
200	0.018	0.07	5.01
250	0.019	0.07	5.01
315	0.0205	0.07	5.01
400	0.0215	0.07	5.01
500	0.02258	0.07	5.01
630	0.02417	0.08	5.01
800	0.02574	0.08	5.01
1000	0.02753	0.08	5.01
1250	0.02973	0.08	5.01
1600	0.03231	0.08	5.01
2000	0.035	0.08	5.01
2500	0.0385	0.085	5.01



**FIGURE A-34 1/3 Octave Filter Summary Graph**



**FIGURE A-35 1/3 OBA 0.4 Hz Filter Response**

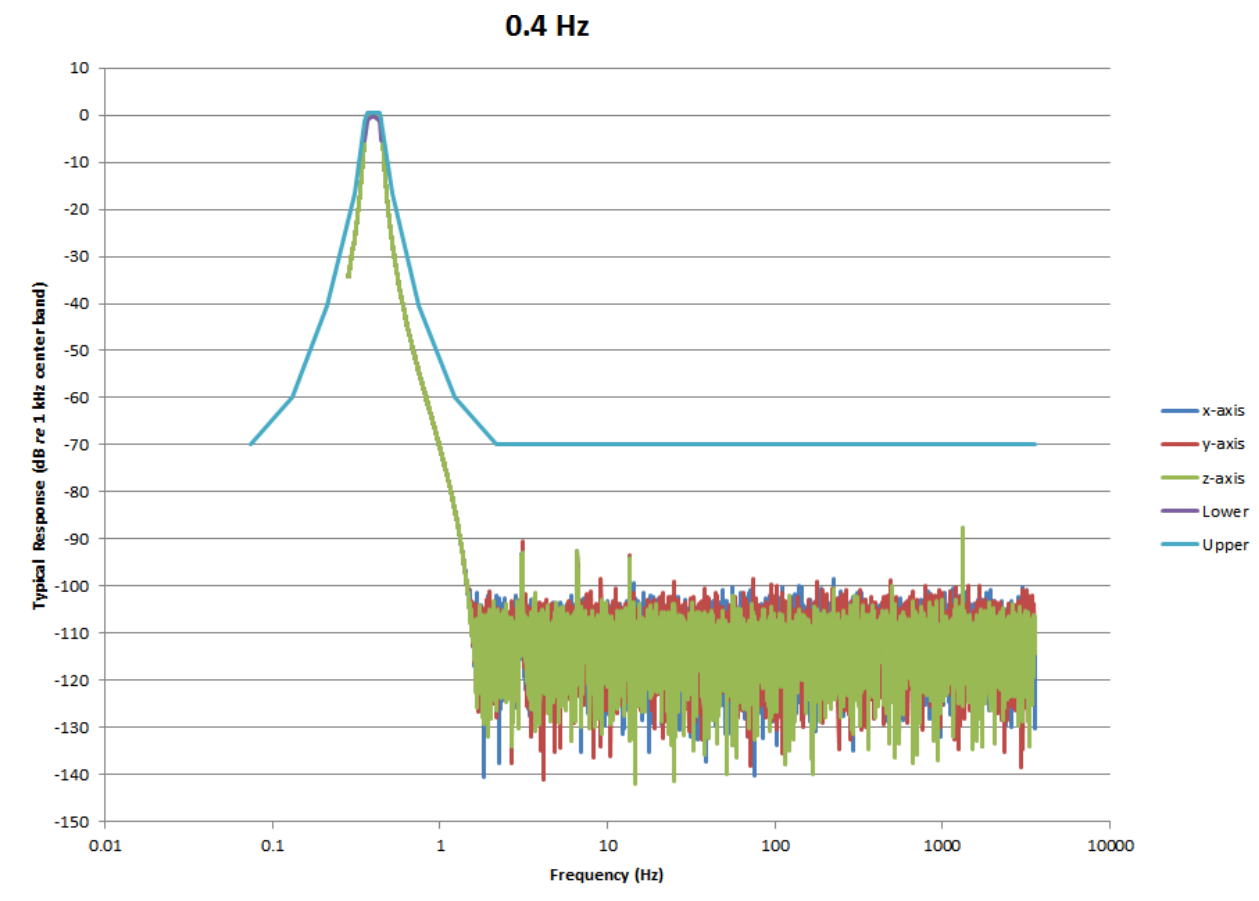


FIGURE A-36 1/3 OBA 0.4 Hz Filter Response: Pass-band

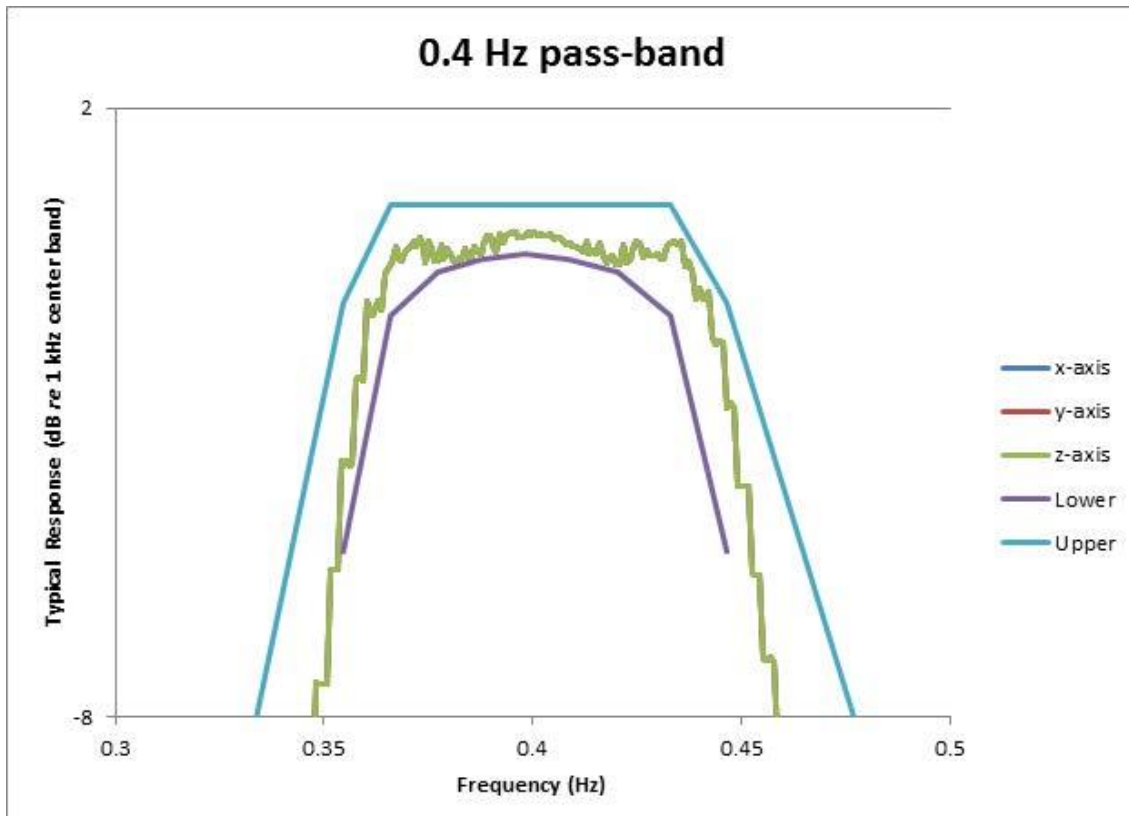
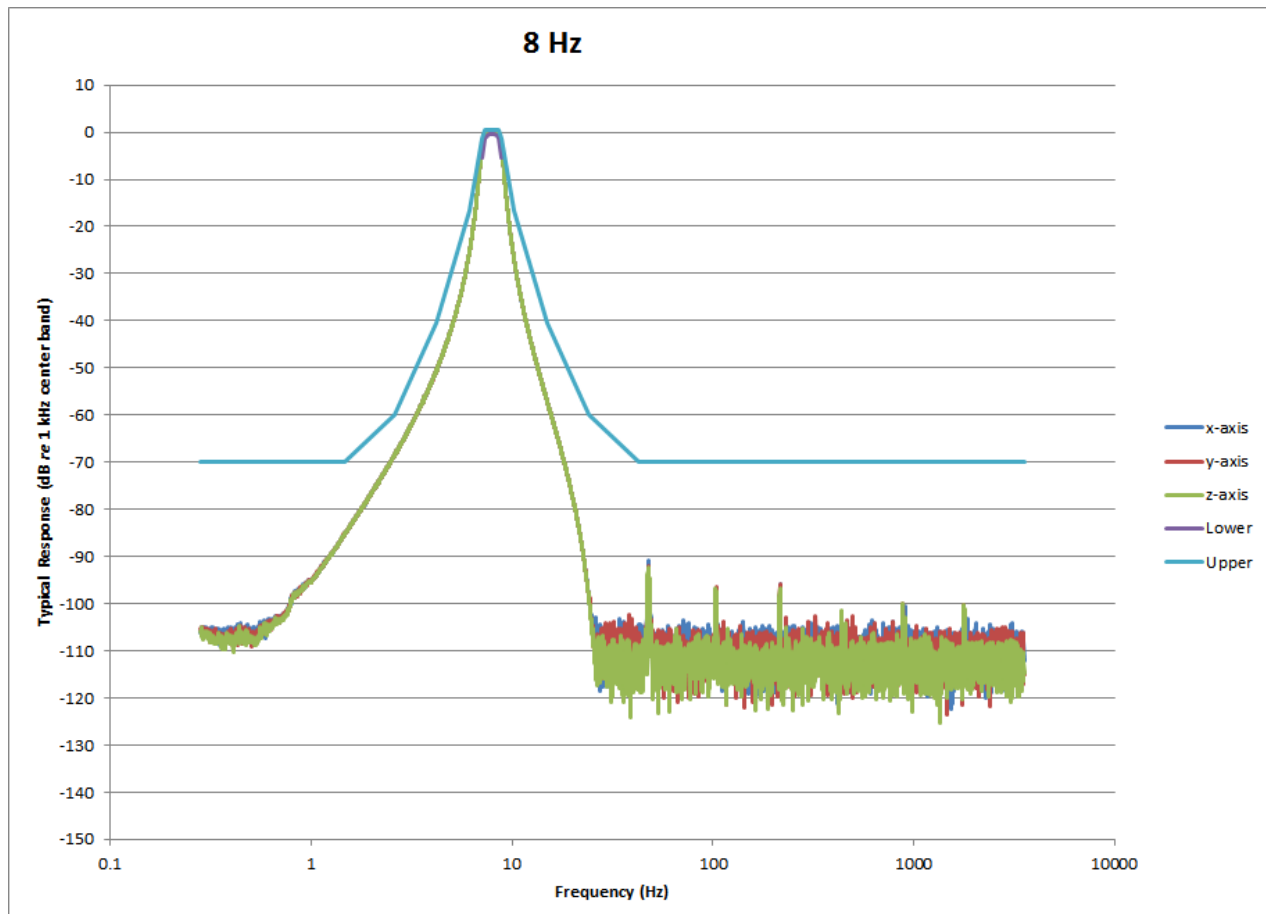
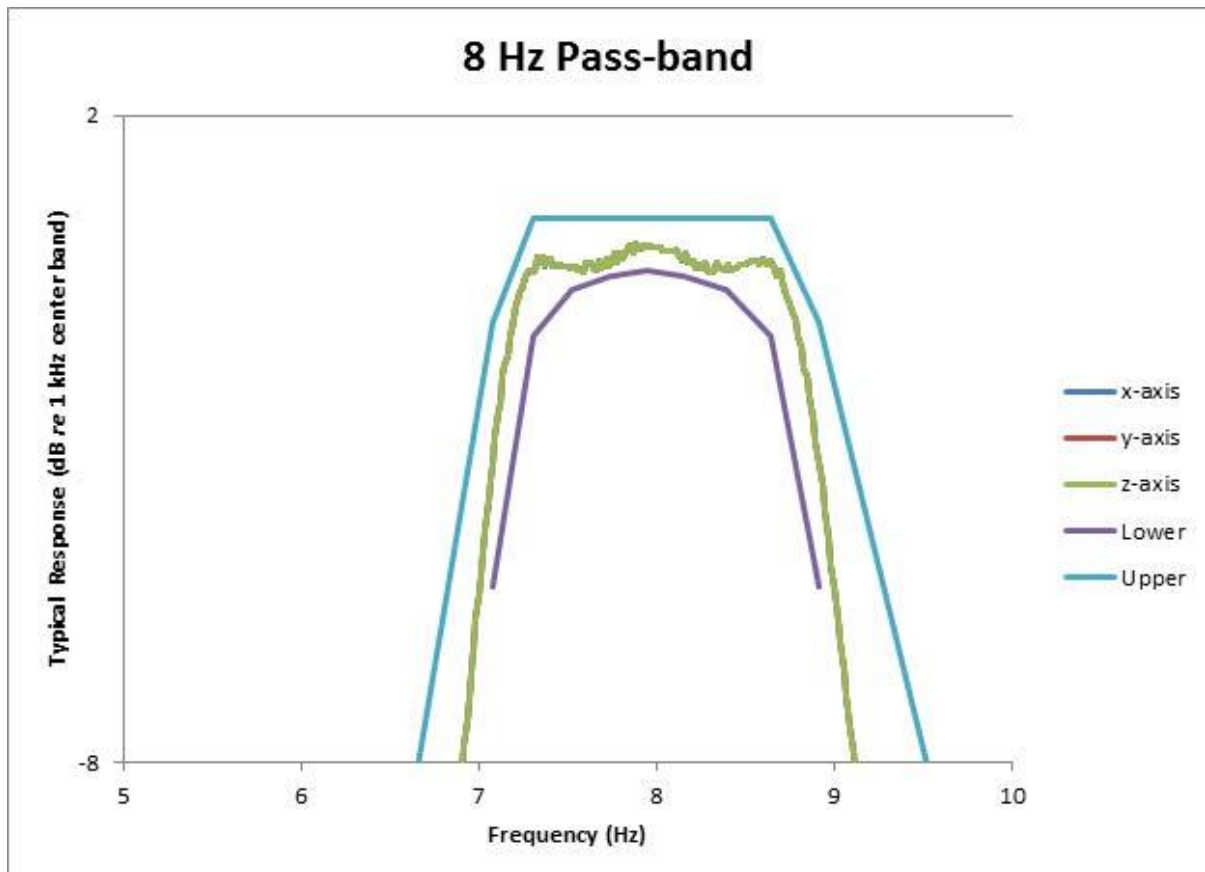


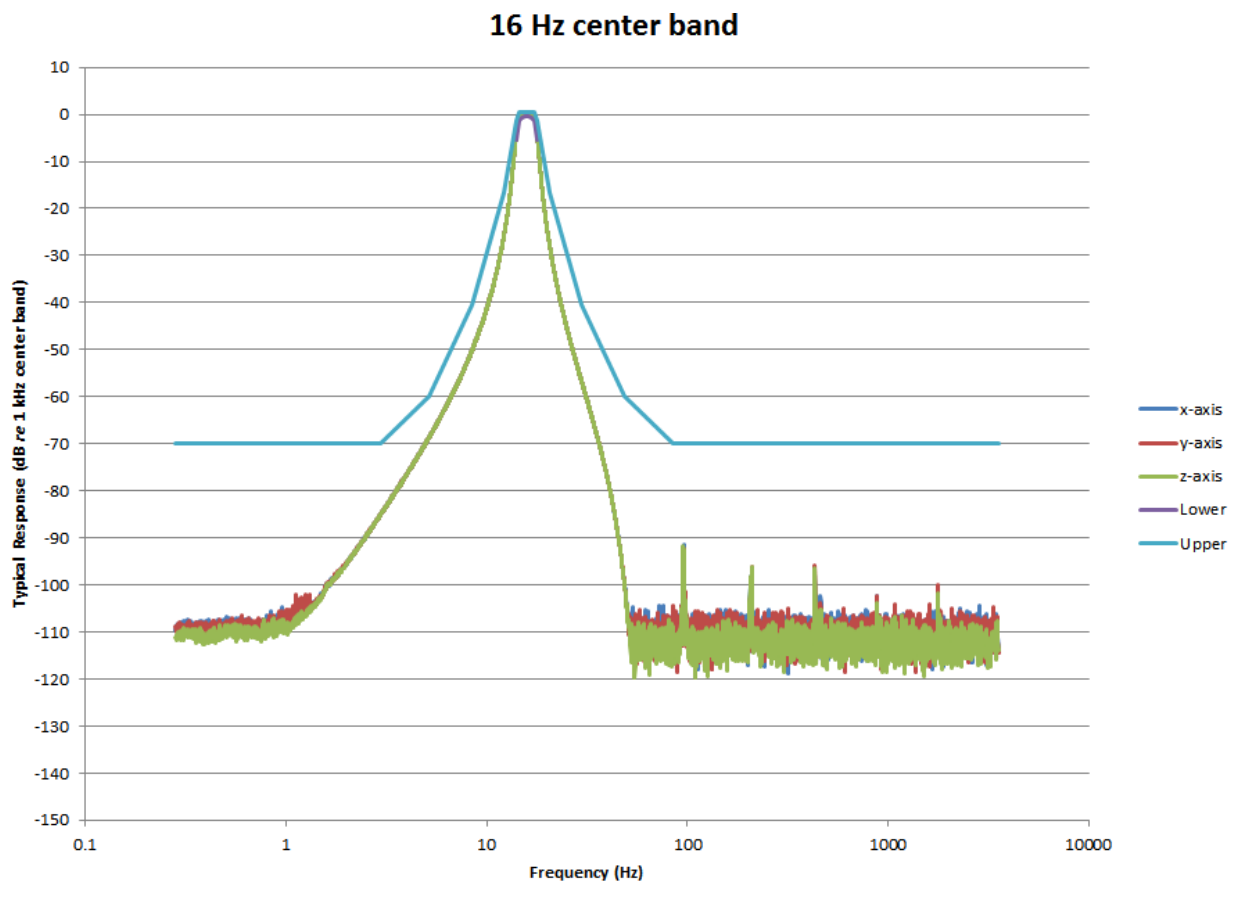
FIGURE A-37 1/3 OBA 8.0 Hz Filter Response



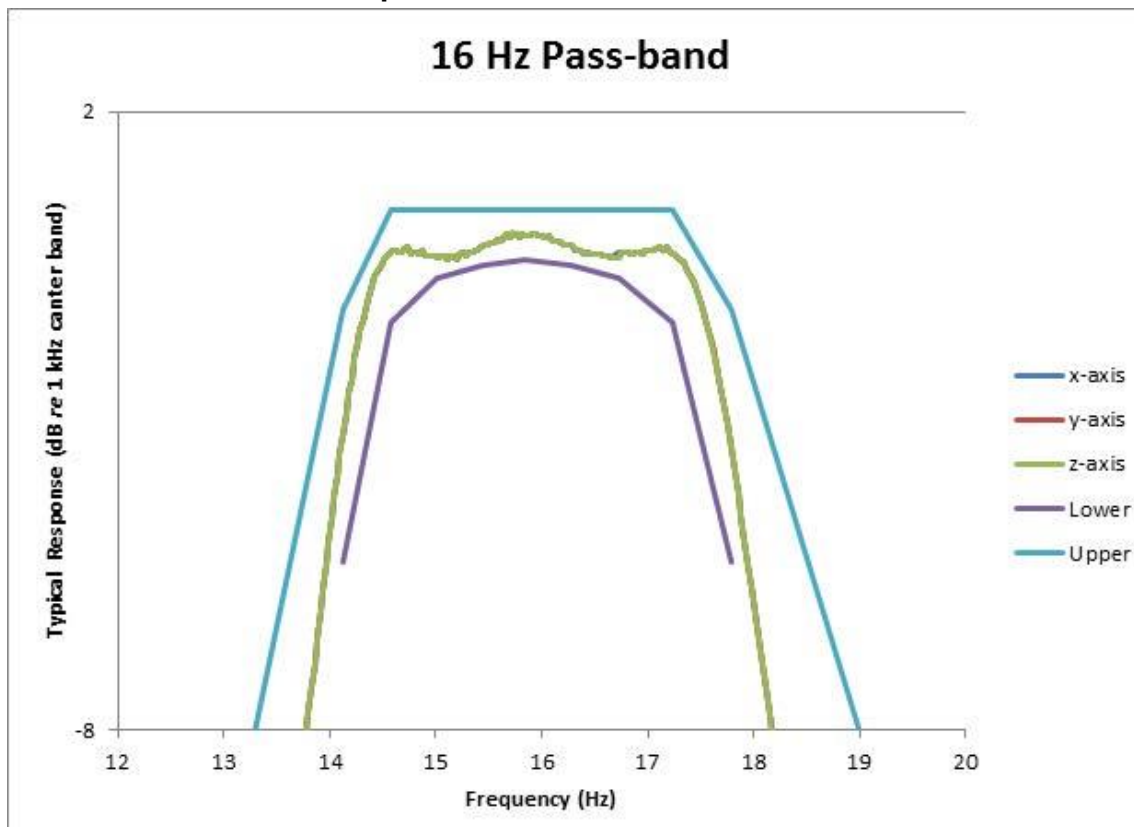
**FIGURE A-38 1/3 OBA 8.0 Hz Filter Response: Pass-band**



**FIGURE A-39 1/3 OBA 16.0 Hz Center Band Filter Response**



**FIGURE A-40 1/3 OBA 16.0 Hz Filter Response: Pass-band**



**FIGURE A-41 1/3 OBA 80.0 Hz Filter Response**

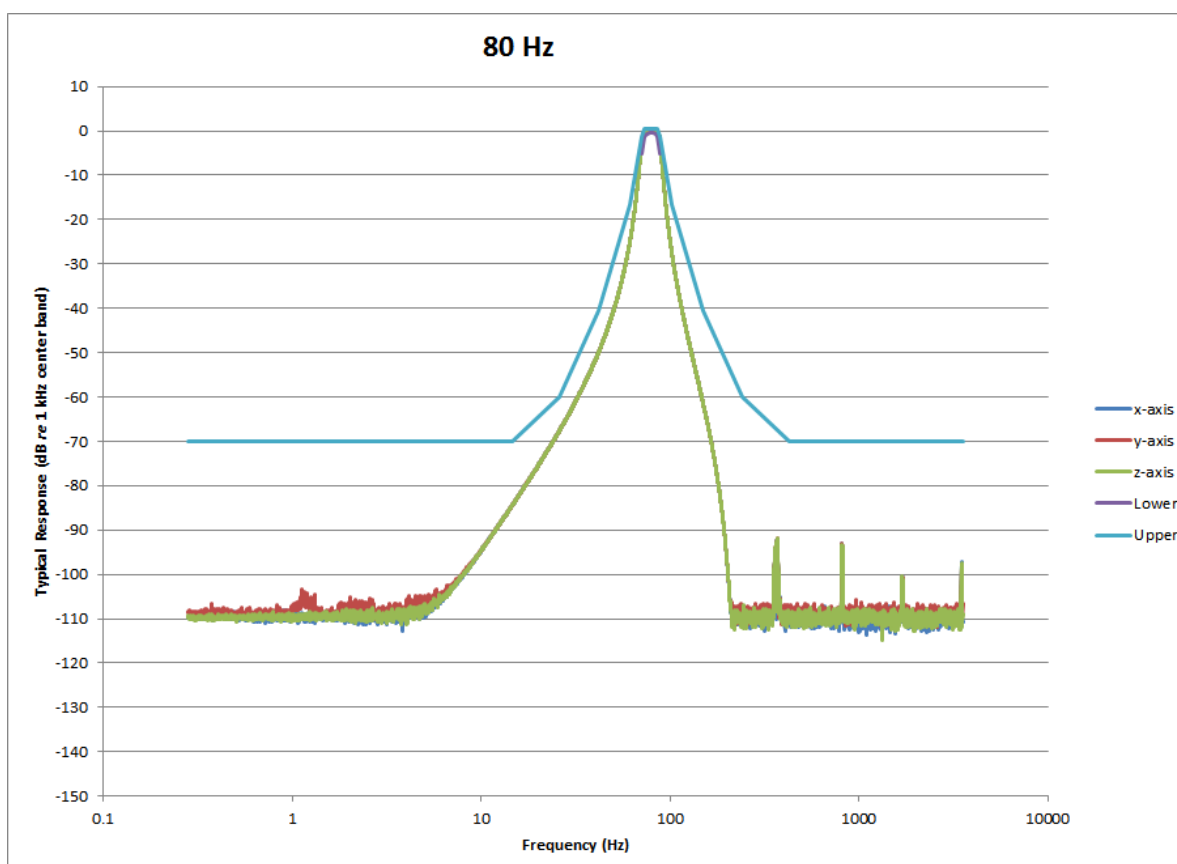
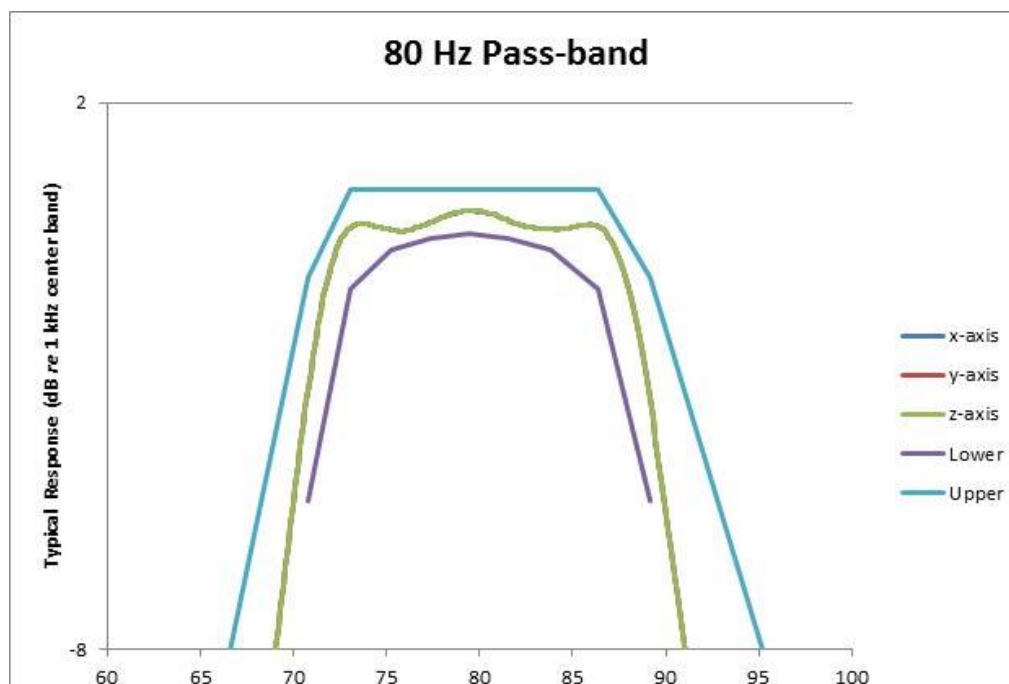


FIGURE A-42 1/3 OBA 80.0 Hz Passband Filter Response



## **A.11 Standards For Human Vibration Measurements**

The Larson Davis HVM200 Human Vibration Meter is a instrument designed for use in assessing vibration as perceived by human beings. The instrument measurement filters meet the requirements of ISO 8041-1:2017 and ISO 8041-2:2021.

Note: The HVM200 does not fully meet the radio frequency immunity requirements of ISO 8041-1:2017 and ISO 8041-2:2021. Section 12.20.8 of the mentioned standards requires disturbances to be no more than 0.2 m/s<sup>2</sup> RMS when subjected to a 10 V/m modulated field across a wide frequency spectrum. Under these test conditions, the HVM200 showed disturbances below 2.5 m/s<sup>2</sup>. Tests were performed using a 10 mV/g sensor (SEN021F).

The standards listed below define methods for the measurement of whole-body and hand-arm vibration.

- ISO 2631-1:1997 Mechanical vibration and shock -- Evaluation of human exposure to whole-body vibration -- Part 1: General requirements
- ISO 2631-5:2004 Evaluation of human exposure to whole-body vibration -- Part 5: Method for evaluation of vibration containing multiple shocks
- ISO 2631-2:2003 Evaluation of human exposure to whole-body vibration -- Part 2: Continuous and shock-induced vibrations in buildings (1 to 80 Hz)
- ISO 2631-4:2001 Mechanical vibration and shock -- Evaluation of human exposure to whole-body vibration -- Part 4: Guidelines for the evaluation of the effects of vibration and rotational motion on passenger and crew comfort in fixed-guide-way transport systems
- ISO 5349-1:2001 Mechanical vibration -- Measurement and evaluation of human exposure to hand-transmitted vibration -- Part 1: General requirements
- ISO 5349-2:2001 Mechanical vibration -- Measurement and evaluation of human exposure to hand-transmitted vibration -- Part 2: Practical guidance for measurement at the workplace
- EN 1032:2003 Mechanical vibration -- Testing of mobile machinery in order to determine the vibration emission value
- ANSI S2.70 Guide for the Measurement and Evaluation of Human Exposure to Vibration Transmitted to the Hand

# Appendix **B** Adapter Resonance and Frequency Response Test

Experimental measurements indicate no resonances within the “Wh” frequency range for the adapters ADP080A, ADP081A and ADP082A as shown in the following sections. Using these adapters does not affect the performance specifications outside of the meter specifications in Appendix A.

**In this appendix:**

B.1.1	ADP080A + SEN041 Mounting, Placement, and Result .....	B-2
B.1.2	ADP081A + SEN041 Mounting, Placement, and Result .....	B-3
B.1.3	ADP082A + SEN041 Mounting, Placement, and Result .....	B-4

## **B.1 Results of Frequency Response Testing**

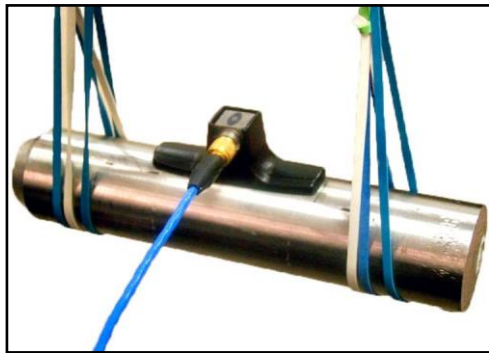
The following frequency response measurements were performed by suspending the test object and exciting it with a modal hammer. The responses were measured in x, y, and z directions using a triaxial accelerometer connected to the test object using the specified adapter. A graphic is included to illustrate the test configuration.

### **Triaxial Accelerometer (SEN041F)**

The triaxial accelerometer used for these tests was a Larson Davis Model SEN041F, with a sensitivity of 10 mV/g.

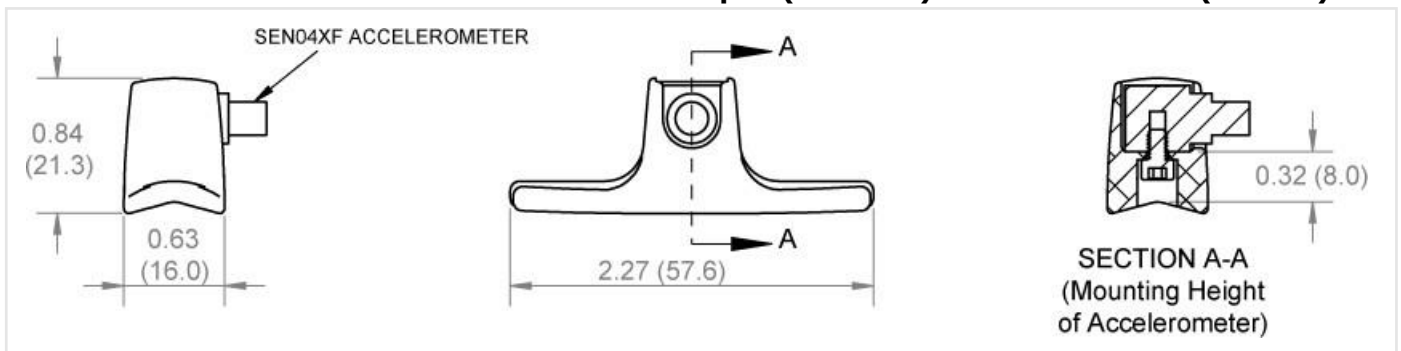
## B.1.1 ADP080A + SEN041 Mounting, Placement, and Result

**FIGURE B-1 Hand Adapter (ADP080A) and Accelerometer (SEN041) Mounting**

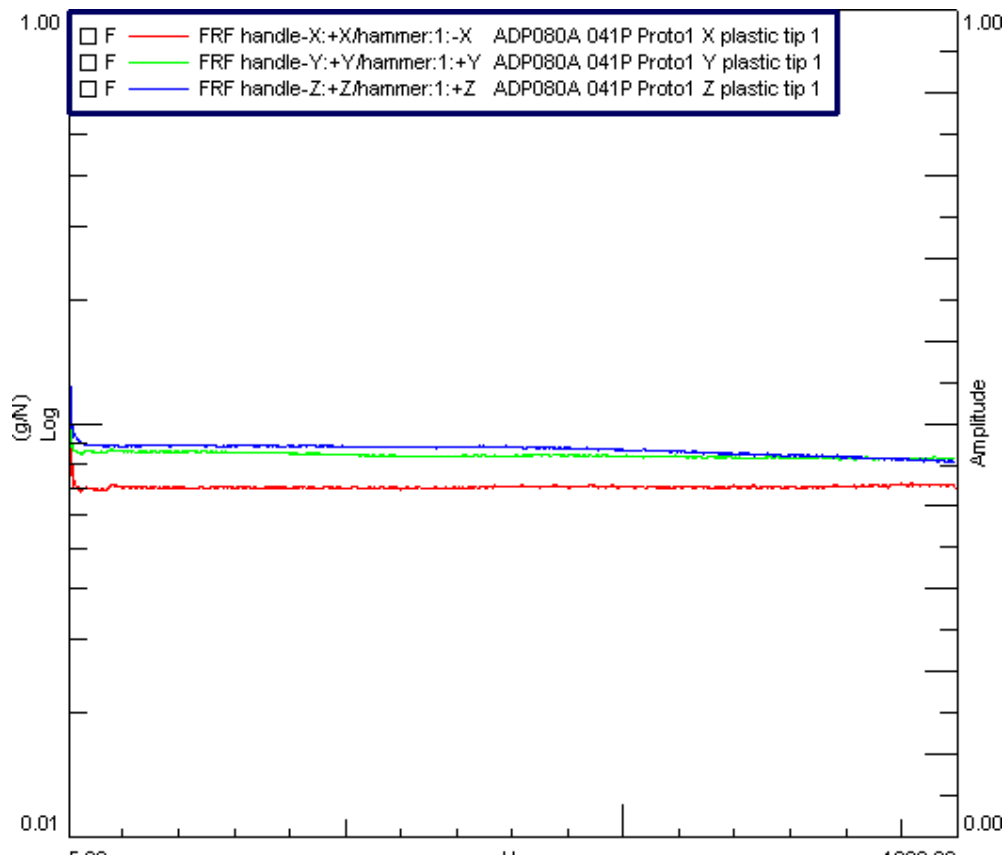


Specification	ADP080A
Total Mass of Vibration Sensor & Mounting System (including sensor, adapter, & mounting screw)	0.67 oz (19 grams)
Mounting Height of Vibration Sensor (distance between sensor and mounting surface)	0.32 oz (8.0 grams)
Adapter dimensions	See Figure B-2

**FIGURE B-2 Dimensions and Placement for Hand Adapter (ADP080A) and Accelerometer (SEN041)**



**FIGURE B-3 Hand Adapter (ADP080A) Frequency Response Function X, Y, and Z**

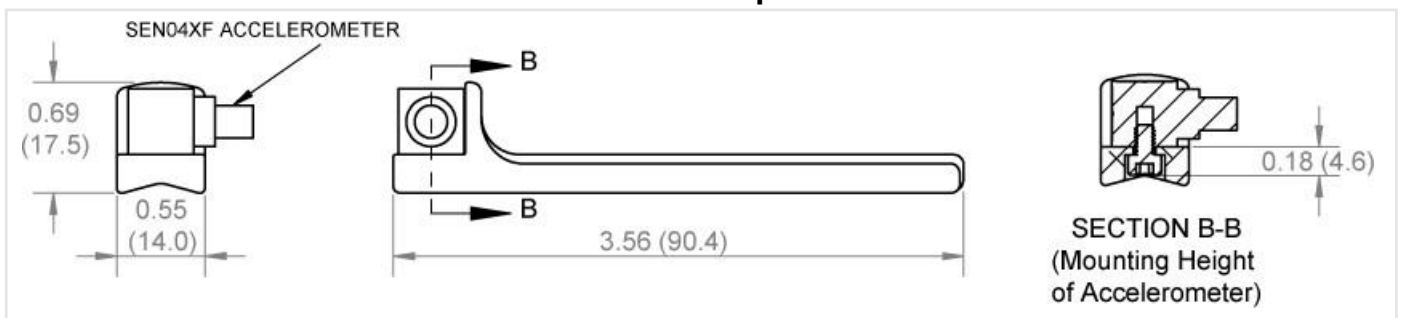


## B.1.2 ADP081A + SEN041 Mounting, Placement, and Result

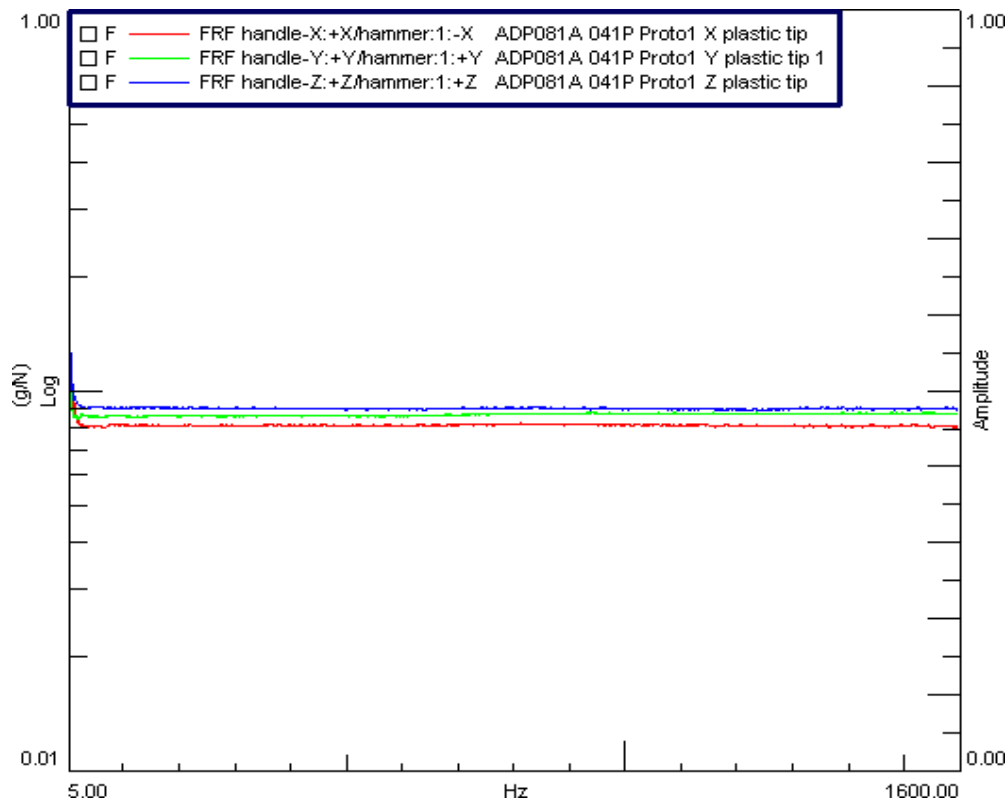
### FIGURE B-4 Handle Adapter and Accelerometer Mounting

Specification	ADP081A
Total Mass of Vibration Sensor & Mounting System (including sensor, adapter, & mounting screw)	0.74 oz (21 grams)
Mounting Height of Vibration Sensor (distance between sensor and mounting surface)	0.18 oz (4.6 grams)
Adapter dimensions	See Figure B-5

### FIGURE B-5 Dimensions and Placement for Handle Adapter and Accelerometer



### FIGURE B-6 Handle Adapter Frequency Response Function X, Y, and Z



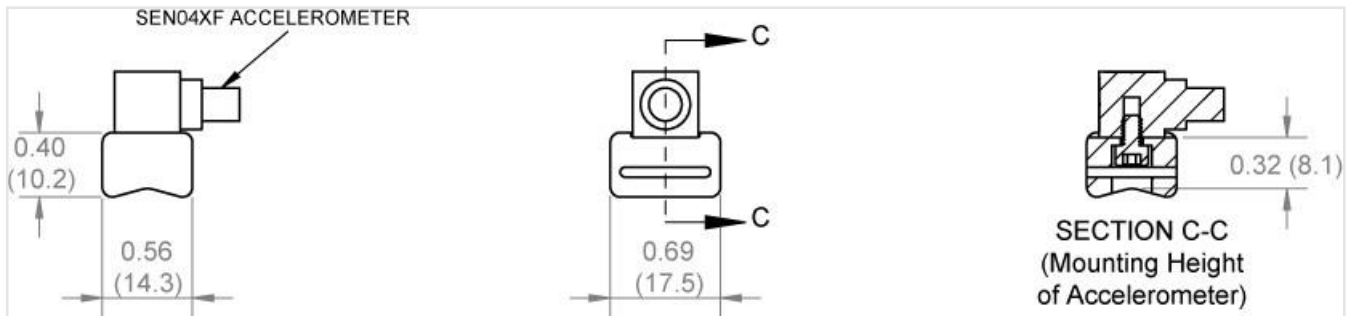


### B.1.3 ADP082A + SEN041 Mounting, Placement, and Result

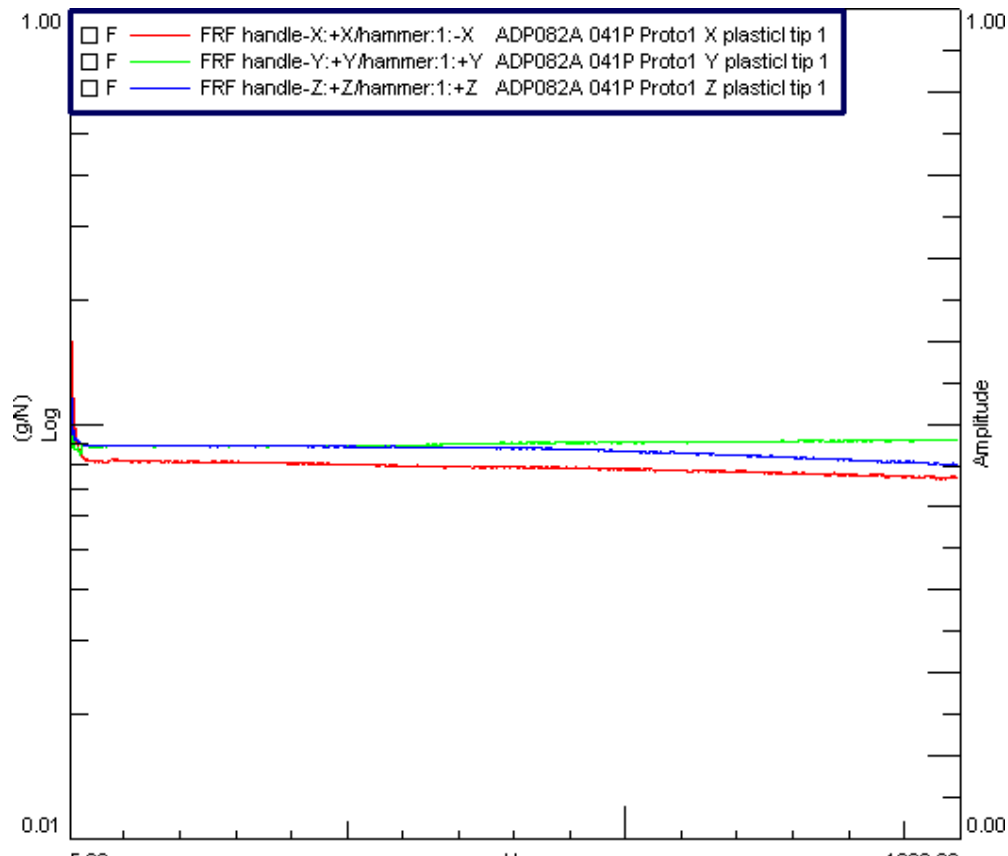
**FIGURE B-7 Clamp Adapter and Accelerometer Placement**

Specification	ADP081A
Total Mass of Vibration Sensor & Mounting System (including sensor, adapter, & mounting screw)	0.35 oz (10 grams)
Mounting Height of Vibration Sensor (distance between sensor and mounting surface)	0.32 oz (8.1 grams)
Adapter dimensions	See Figure B-8

**FIGURE B-8 Dimensions and Placement for Clamp Adapter and Accelerometer**



**FIGURE B-9 Clamp Adapter Frequency Response Function X, Y, and Z**



# Appendix Glossary of Terms

The following table contains definitions and calculations for terminology used in the HVM200 manual.

Term	Equation Description
<b>RMS Acceleration</b>	$A_{eq} = \sqrt{\frac{1}{T} \int_0^T a_w^2(t) dt}$ <p> <i>T</i> = Integration time in seconds.  <i>a<sub>w</sub>(t)</i> = instantaneous acceleration.  <i>t</i> = Time, in seconds.                 </p> <p>The <i>A<sub>eq</sub></i> integration time is from Run to Reset; the display is updated once per second.</p>
<b>RMS Acceleration in Decibels</b>	$A_{eq} = 20 \text{Log} \left[ \frac{\sqrt{\frac{1}{T} \int_0^T a_w^2(t) dt}}{a_o} \right] \text{ dB}$ <p><i>a<sub>o</sub></i> = reference acceleration, 10<sup>-6</sup> m/s<sup>2</sup> or 10<sup>-5</sup> m/s<sup>2</sup> (user selectable)</p>
<b>Allowed Exposure Time</b>	$\left[ \frac{(a \text{ m/s}^2)}{L} \right] / (A_{eq})^2 \times 8 \text{ hours}$ <p> <i>a<sub>L</sub></i> is user selectable.                      A8Exp: <i>a<sub>L</sub></i> typically = 5                      A8Act: <i>a<sub>L</sub></i> typically = 2.5                 </p>
<b>Energy Equivalent RMS Acceleration</b>	<p>The HVM200 measures the following quantities:</p> $A(8) = \sqrt{\frac{1}{8 \text{ Hours}} \int_0^T a_w^2(t) dt}$ $A(4) = \sqrt{\frac{1}{4 \text{ Hours}} \int_0^T a_w^2(t) dt}$ $A(2) = \sqrt{\frac{1}{2 \text{ Hours}} \int_0^T a_w^2(t) dt}$ $A(1) = \sqrt{\frac{1}{1 \text{ Hours}} \int_0^T a_w^2(t) dt}$

Term	Equation Description
<b>Exposure Points (PE)</b>	$P_E = \left( \frac{ka_w}{a_{exp}} \right)^2 \frac{T}{8 \text{ hours}} 100$ <p> <i>k</i> = the multiplying sum factor for the individual axis.  <i>a<sub>w</sub></i> = the vibration magnitude in m/s<sup>2</sup>.  <i>T</i> = the exposure time in hours.  <i>a<sub>exp</sub></i> = the exposure action value </p> <p>The summation measurement exposure points are the maximum of the three axes exposure points.</p>
<b>Running RMS Acceleration LINEAR</b>	$Arms = \sqrt{\frac{1}{\tau} \int_{(t_o - \tau)}^{t_o} a_w^2(t) dt}$ <p> <i>τ</i> = Integration time, in seconds.  <i>t<sub>o</sub></i> = Observation time </p> <p>The linear Arms integration time is controlled by the Averaging time setting; a new linear Arms value is calculated and displayed at the end of each integration period.</p>
<b>Running RMS Acceleration EXPONENTIAL</b>	$Arms = \sqrt{\frac{1}{\tau} \int_{(-\infty)}^{t_o} a_w^2(t) \exp\left(\frac{t-t_o}{\tau}\right) dt}$ <p> <i>τ</i> = Time constant of the measurement. </p> <p>An averaging time of SLOW is equivalent to a time constant of 1 second.</p>
<b>Vibration Dose Value (VDV)</b>	$VDV = \left( \int_0^T a_w^4(t) dt \right)^{\frac{1}{4}}$ <p>The <i>VDV</i> integration time is from Run to Reset; the display is updated once per second. The <i>VDV</i> is not calculated for units of dB or g.</p> <p>For whole body vibration mode:</p> $VDV_{sum} = \max(VDV_x + VDV_y + VDV_z)$
<b>Maximum Transient Vibration Value (MTVV)</b>	<p><i>A<sub>max</sub></i> = maximum reading of all Arms readings from Run to Reset. The display is updated at the end of each Averaging time period.</p> <p>The vector sum is continuously compared to previous values for <i>MTVV</i>, <i>A<sub>peak</sub></i>, and <i>A<sub>max</sub></i>. Then, the highest value in the current averaging time period is reported for <i>MTVV</i>, <i>A<sub>peak</sub></i>, and <i>A<sub>max</sub></i>. This explains how the <i>A<sub>max</sub></i> value may not occur at the same time for x, y, and z; and also why a vector sum of the x, y, and z <i>A<sub>max</sub></i> may not equal the reported sum value.</p>

Term	Equation Description
<b>Minimum Transient Vibration Value (MIN)</b>	<p>Amin = minimum reading of all Arms readings from Run to Reset. The display is updated at the end of each Averaging time period.</p> <p>The vector sum is continuously compared to previous values for MIN, and Amin. Then, the lowest value in the current averaging time period is selected for Amin. This explains how the Amin value may not occur at the same time for x, y, and z; and also why a vector sum of the x, y, and z Amin may not equal the reported sum value.</p>
<b>Long Term Maximum Peak</b>	<p>Amp = peak level of the instantaneous weighted acceleration, <math>a_w(t)</math>; measured over the entire measurement period, from Run to Reset.</p> <p>The displayed Amp value is updated once per second.</p>
<b>Short Term Maximum Peak</b>	<p>Peak = peak level of the instantaneous weighted acceleration, <math>a_w(t)</math>; measured during one Averaging time period.</p> <p>The peak measurement period is controlled by the Averaging time setting; a new Peak value is calculated and displayed at the end of each Averaging time period.</p>
<b>Summed Instantaneous Acceleration</b>	$[K_x a_{wx}(t)]^2 + [K_y a_{wy}(t)]^2 + [K_z a_{wz}(t)]^2$ <p><math>a_{w\Sigma}(t)</math> = instantaneous, summed acceleration  <math>a_{wx}(t), a_{wy}(t), a_{wz}(t)</math> = X, Y, and Z axis instantaneous acceleration  <math>K_x, K_y, K_z</math> = X, Y, and Z axis Sum Factors</p> <p>The HVM200 uses the formula above to calculate the instantaneous, summed acceleration, <math>a_{w\Sigma}(t)</math>. This value is then used to calculate a sum quantity for the <math>A_{rms}, A_{min}, A_{max}, A_{mp}, A_{eq}, Peak, VDV,</math> and <math>PE</math>.  K factors affect only the sum value, not individual axis data.  For Hand/Arm and Vibration measurements, the K factors will always be 1, regardless of user settings.</p>

# Appendix **D** Regulatory Compliance

The HVM200 contains a **ATWILC1000-MR110PB** module that has regulatory approval for the following countries:

– United States/FCC ID: ZOC-LDHVM200B

– Canada/ISED: IC: 9732A-LDHVM200B

– Europe/CE

– Japan/MIC: 005-101763



– Korea/KCC: R-CRM-mcp-WILC1000MR110P



– China/SRRC: CMIIT ID: 2018DJ1313

– Taiwan/NCC: CCAN18LP0310T7



根據 NCC LP0002 低功率射頻器材技術規範 \_ 章節 3.8.2 : 取得審驗證明之低功率射頻器材, 非經核准, 公司、商號或使用者均不得擅自變更頻率、加大功率或變更原設計之特性及功能。

低功率射頻器材之使用不得影響飛航安全及干擾合法通信; 經發現有干擾現象時, 應立即停用, 並改善至無干擾時方

得繼續使用。

前述合法通信, 指依電信管理法規定作業之無線電通信。

低功率射頻器材須忍受合法通信或工業、科學及醫療用電波輻射性電機設備之干擾。

## FCC

This device complies with part 15 of the FCC rules. Operation is subject to the following two conditions:

(1) This device may not cause harmful interference, and (2) this device must accept any interference received, including interference that may cause undesired operation. Any changes or modifications not expressly approved by manufacturer could void the user's authority to operate the equipment.

**IMPORTANT!** Any changes or modifications not expressly approved by the party responsible for compliance could void the user's authority to operate this equipment.

## Industry Canada

This device contains license-exempt transmitter(s)/receiver(s) that comply with Innovation, Science and Economic Development Canada's license-exempt RSS(s). Operation is subject to the following two conditions:

(1) This device may not cause interference;

(2) This device must accept any interference, including interference that may cause undesired operation of the device.

L'émetteur/récepteur exempt de licence contenu dans le présent appareil est conforme aux CNR d'Innovation, Sciences et Développement économique Canada applicables aux appareils radio exempts de licence. L'exploitation est autorisée aux deux conditions suivantes:

1. L'appareil ne doit pas produire de brouillage;

2. L'appareil doit accepter tout brouillage radioélectrique subi, même si le brouillage est susceptible d'en compromettre le fonctionnement.

This radio transmitter [IC: 20266-ATWILC1000] has been approved by

Innovation, Science and Economic Development Canada to operate with the antenna types listed below, with the maximum permissible gain indicated. Antenna types not included in this list that have a gain greater than the maximum gain indicated for any type listed are strictly prohibited for use with this device.

Le présent émetteur radio [IC: 20266-ATWILC1000 and IC: 20266-WILC1000UB] a été approuvé par Innovation, Sciences et Développement économique Canada pour fonctionner avec les types d'antenne énumérés cidessous et ayant un gain admissible maximal. Les types d'antenne non inclus dans cette liste, et dont le gain est supérieur au gain maximal indiqué pour tout type figurant sur la liste, sont strictement interdits pour l'exploitation de l'émetteur.

## 47 CFR 15.505- FCC

### Class B

NOTE: This equipment has been tested and found to comply with the limits for a Class B digital device, pursuant to part 15 of the FCC Rules. These limits are designed to provide reasonable protection against harmful interference in a residential installation. This equipment generates, uses and can radiate radio frequency energy and, if not installed and used in accordance with the instructions, may cause harmful interference to radio communications. However, there is no guarantee that interference will not occur in a particular installation. If this equipment does cause harmful interference to radio or television reception, which can be determined by turning the equipment off and on, the user is encouraged to try to correct the interference by one or more of the following measures:

- Reorient or relocate the receiving antenna.
- Increase the separation between the equipment and receiver.
- Connect the equipment into an outlet on a circuit different from that to which the receiver is connected.
- Consult the dealer or an experienced radio/ TV technician for help.



### GMGA MEASURING

**Address: No. 33 Alley 99/120 Dinh Cong Ha, Dinh Cong Ward, Hoang Mai District, 10000 Hanoi City, Vietnam**

**Telephone: [+84 845 969 336](tel:+84845969336)**

**Email: [info@gmga.vn](mailto:info@gmga.vn)**

**Website: <https://gmga.vn/>**